



Air Conditioning Technical Data

Condensing units for air handling applications (pair)



EEEN14-205

ERQ-AW1

TABLE OF CONTENTS

ERQ-AW1

1	Features	2
2	Specifications	3
	Technical Specifications	3
	Electrical Specifications	4
3	Options	6
4	Selection procedure	7
5	Combination table	8
6	Capacity tables	9
	Cooling Capacity Tables	9
	Heating Capacity Tables	15
	Capacity Correction Factor	21
7	Dimensional drawings	22
8	Centre of gravity	24
9	Piping diagrams	26
10	Wiring diagrams	29
	Wiring Diagrams - Single Phase	29
11	External connection diagrams	31
12	Sound data	32
	Sound Power Spectrum	32
	Sound Pressure Spectrum	33
13	Installation	34
	Installation Method	34
	Fixation and Foundation of Units	35
14	Operation range	36

1 Features

- Wide range of units offers maximum application potential and flexible control options
- Connect ERQ to a Biddle air curtain for a reliable and effective method of separating outdoor and indoor climates, offering a payback period of less than 1.5 years compared to electric air curtains
- Connect ERQ to an air handling unit to provide optimized air conditions such as fresh air and humidity control, both in heating and cooling, for small warehouses, showrooms and offices
- Control box and expansion valve kit are required for each combination plus an air handling unit

1



2 Specifications

2-1 Technical Specifications				ERQ125AW1	ERQ200AW1	ERQ250AW1	
Capacity range			HP	5	8	10	
Cooling capacity	Nom.		kW	14.0 (1)	22.4 (1)	28.0 (1)	
Heating capacity	Nom.		kW	16.0 (2)	25.0 (2)	31.5 (2)	
Power input	Cooling	Nom.	kW	3.52 (1)	5.22 (1)	7.42 (1)	
	Heating	Nom.	kW	4.00 (2)	5.56 (2)	7.70 (2)	
Capacity control	Method			Inverter controlled			
	Cooling	Max.	%	100			
EER				3.98 (1)	4.29 (1)	3.77 (1)	
COP				4.00 (2)	4.50 (2)	4.09 (2)	
Connection ratio	Outdoor units	with only ventilation units connected	Minimum	-			
			Maximum	-			
	Ventilation units	when combined with VRV® indoor units	Maximum	-			
Casing	Colour			Daikin White			
	Material			Painted galvanized steel plate			
Dimensions	Unit	Height	mm	1,680			
		Width	mm	635	930		
		Depth	mm	765			
	Packed unit	Height	mm	1,855			
		Width	mm	796	1,055		
		Depth	mm	860			
Weight	Unit		kg	159	187	240	
	Packed unit		kg	182	217	273	
Packing	Material			Carton			
	Weight			kg	3.8	4.02	
Packing 3	Material			Plastic			
	Weight			kg	0.215	0.265	
Heat exchanger	Length		mm	1,483	1,778		
	Rows	Quantity		54			
	Fin pitch		mm	2			
	Passes	Quantity		8	18		
	Face area		m ²	1.762	2.112		
	Stages	Quantity		2			
	Empty tubeplate hole	Quantity		0			
	Tube type			ø8 Hi-XSS			
	Fin	Type		Non-symmetric waffle louvre			
		Treatment		Hydrophilic and corrosion resistant			
	Compressor	Quantity			1	2	
Model			Inverter				
Type			Hermetically sealed scroll compressor				
Speed		rpm		6,300	7,980	6,300	
Output		W		2,800	3,800	1,200	
Crankcase heater			W				
			33				
Compressor 2	Model			-	ON - OFF		
	Type			-	Hermetically sealed scroll compressor		
	Speed	rpm		-	2,900		
	Output	W		-	4,500		
	Crankcase heater			W	-	33	

2 Specifications

2

2-1 Technical Specifications				ERQ125AW1	ERQ200AW1	ERQ250AW1	
Fan	Type			Propeller fan			
	Discharge direction			Vertical			
	Quantity			1			
	Air flow rate	Cooling	Nom.	m ³ /min	95	171	185
		Heating	Nom.	m ³ /min	95	171	185
External static pressure	Max.		Pa	78			
Fan motor	Quantity			1			
	Model			Brushless DC motor			
	Output		W	350.00	750.00		
Sound power level	Nom.		dBA	72	78		
Sound pressure level	Nom.		dBA	54	57	58	
Operation range	Cooling	Min.	°CDB	-5			
		Max.	°CDB	43			
	Heating	Min.	°CWB	-20			
		Max.	°CWB	15			
	On coil temperature	Heating	Min.	°CDB	10		
		Cooling	Max.	°CDB	35		
Refrigerant	Type			R-410A			
	Charge		kg	6.2	7.7	8.4	
	Control			Electronic expansion valve			
	Circuits	Quantity		1			
Refrigerant oil	Type			Synthetic (ether) oil			
	Charged volume		l	1.7	2.1	4.3	
Piping connections	Liquid	Type		Braze connection			
		OD	mm	9.52			
	Gas	Type		Braze connection			
		OD	mm	15.9	19.1	22.2	
	Heat insulation			Both liquid and gas pipes			
Defrost method				Reversed cycle			
Defrost control				Sensor for outdoor heat exchanger temperature			
Safety devices	Item	01	High pressure switch				
		02	Fan motor driver overload protector				
		03	Overcurrent relay				
		04	Inverter overload protector				
		05	PC board fuse				

Standard Accessories : Installation manual; Quantity : 1;

Standard Accessories : Operation manual; Quantity : 1;

Standard Accessories : Connection pipes; Quantity : 4;

2-2 Electrical Specifications				ERQ125AW1	ERQ200AW1	ERQ250AW1	
Power supply	Name			W1			
	Phase			3N~			
	Frequency		Hz	50			
	Voltage		V	400			
	Voltage range	Min.	%	-10			
		Max.	%	10			
Current	Nominal running current (RLA)	Cooling	A	5.1	7.5	11.3	
		Heating	A	5.8	8.2	11.1	
	Starting current	Cooling	A	-	-	74 (1)	
	Zmax	Text		-	0.27		
	Minimum circuit amps (MCA)		A	11.9	18.5	21.6	
	Maximum fuse amps (MFA)		A	16	25		
	Total overcurrent amps (TOCA)		A	15.6	16.5	31.5	
	Full load amps (FLA)	Fan motor		A	0.4	0.7	0.9
		Minimum Ssc value		kVa	-	910	838

4

2 Specifications

2-2 Electrical Specifications			ERQ125AW1	ERQ200AW1	ERQ250AW1
Wiring connections	For power supply	Quantity	5		
		Remark	Earth wire included		
	For connection with indoor	Quantity	2		
		Remark	F1,F2		
Power supply intake			Both indoor and outdoor unit		

2

Notes

- (1) Cooling: indoor temp. 27°CDB, 19.0°CWB; outdoor temp. 35°CDB; equivalent piping length: 5m; level difference: 0m
- (2) Heating: indoor temp. 20°CDB; outdoor temp. 7°CDB, 6°CWB; equivalent refrigerant piping: 5m; level difference: 0m
- (3) Sound values are measured in a semi-anechoic room.
- (4) Sound power level is an absolute value that a sound source generates.
- (5) Sound pressure level is a relative value, depending on the distance and acoustic environment. For more details, please refer to the sound level drawings.
- (6) MFA is used to select the circuit breaker and the ground fault circuit interrupter (earth leakage circuit breaker).
- (7) Maximum allowable voltage range variation between phases is 2%.
- (8) RLA is based on following conditions: indoor temp. 27°CDB, 19°CWB; outdoor temp. 35°CDB
- (9) Select wire size based on the value of MCA
- (10) TOCA means the total value of each OC set.
- (11) Voltage range: units are suitable for use on electrical systems where voltage supplied to unit terminal is not below or above listed range limits.
- (12) FLA means the full load amps of the fan motor.
- (13) In accordance with EN/IEC 61000-3-11, respectively EN/IEC 61000-3-12, it may be necessary to consult the distribution network operator to ensure that the equipment is connected only to a supply with $Z_{sys} \leq Z_{max}$, respectively $S_{sc} \geq$ minimum S_{sc} value.
- (14) EN/IEC 61000-3-11: European/international technical standard setting the limits for voltage changes, voltage fluctuations and flicker in public low-voltage supply systems for equipment with rated $\leq 75A$
- (15) EN/IEC 61000-3-12: European/international technical standard setting the limits for harmonic currents produced by equipment connected to public low-voltage system with input current $> 16A$ and $\leq 75A$ per phase
- (16) Short-circuit power
- (17) system impedance
- (18) MSC means the maximum current during start up of the compressor

3 Options

3 - 1 Options

3

ERQ-AW1

N°	Item	ERQ125A7W1B	ERQ200A7W1B ERQ250A7W1B
1	Cool/heat selector	KRC19-26A6	
2	One option per module is required	KJB111A	
3	Central drain pan kit	KWC26B160	KWC26B280

4TW32031-4

Notes:

1. All options are kits.
2. Only 1 option per installation is needed.
3. One option per module is required
4. The option should be installed inside the outdoor unit.

4 Selection procedure

4 - 1 Selection Procedure

ERQ-AW1

Integrated heating capacity coefficient

The heating capacity tables do not take account of the reduction in capacity, when frost has accumulated or while the defrosting operation is in progress. The capacity values, which take these factors into account, in other words, the integrated heating capacity values, can be calculated as follows

Formula:

Integrated heating capacity = A

Value given in table of capacity characteristics = B

Integrating correction factor for frost accumulation (kW) = C

$A = B \times C$

Correction factor for finding integrated heating capacity

Inlet port temperature of heat exchanger (°C/RH 85%)	-7	-5	-3	0	3	5	7
Integrating correction factor for frost accumulation	0,96	0,93	0,87	0,81	0,83	0,89	1,0

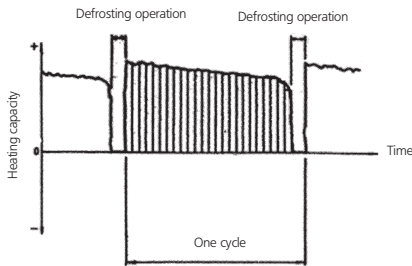

Note:

- The figures shows that the integrated heating capacity expresses the integrated capacity for a single cycle (from defrost operation to defrost operation) in terms of time.

Please note that, when there is an accumulation of snow against the outside surface of the outdoor unit heat exchanger, there will always be a temporary reduction in capacity, although this will of course vary in degree in accordance with a number of other factors, such as the outdoor temperature (°CDB), relative humidity (RH) and the amount of frosting which occurs.

3TW27232-7

5 Combination table

5 - 1 Combination Table

5

ERQ-AW1

Combination table

Outdoor unit		Control box		Expansion valve kit						
		EKEQDCBV3	EKEQFCBV3	EKEXV63	EKEXV80	EKEXV100	EKEXV125	EKEXV140	EKEXV200	EKEXV250
1 ph	ERQ100	P	P	P	P	P	P	-	-	-
	ERQ125	P	P	P	P	P	P	P	-	-
	ERQ140	P	P	-	P	P	P	P	-	-
3 ph	ERQ125	P	P	P	P	P	P	P	-	-
	ERQ200	P	P	-	-	P	P	P	P	P
	ERQ250	P	P	-	-	-	P	P	P	P

Heat pump

P: Pair: Combination depending on AHU heat exchanger volume and capacity

EKEXV Class	Allowed heat exchanger volume (dm ³)		Allowed heat exchanger capacity (kW)	
	Minimum	Maximum	Minimum	Maximum
63	1.66	2.08	6.3	7.8
80	2.09	2.64	7.9	9.9
100	2.65	3.3	10	12.3
125	3.31	4.12	12.4	15.4
140	4.13	4.62	15.5	17.6
200	4.63	6.6	17.7	24.6
250	6.61	8.25	24.7	30.8

Saturated suction temperature (SST) = 6°C, Superheat (SH) = 5K
 Air temperature = 27°CDB/19°CWB

If conflicting result occurs, capacity selection has priority over volume.

3TW32009-1

6 Capacity tables

6 - 1 Cooling Capacity Tables

ERQ125AW1 Cooling

TC: Total capacity; kW; PI: Power Input; kW (Comp. + Outdoor fan motor)

Combination % kW (Capacity index)	Outdoor air temp. (°CDB)	Indoor air temp. °CWB															
		14.0 °CWB 20.0 °CDB		16.0 °CWB 23.0 °CDB		18.0 °CWB 26.0 °CDB		19.0 °CWB 27.0 °CDB		20.0 °CWB 28.0 °CDB		22.0 °CWB 30.0 °CDB		24.0 °CWB 32.0 °CDB			
		TC	PI	TC	PI	TC	PI	TC	PI	TC	PI	TC	PI	TC	PI		
100% 14.00 kW (125)	10	9.45	1.21	11.3	1.47	13.1	1.74	14.0	1.88	14.9	2.02	16.7	2.31	17.7	2.39		
	12	9.45	1.23	11.3	1.50	13.1	1.78	14.0	1.92	14.9	2.06	16.7	2.36	17.5	2.38		
	14	9.45	1.26	11.3	1.53	13.1	1.81	14.0	1.95	14.9	2.10	16.7	2.40	17.2	2.37		
	16	9.45	1.28	11.3	1.55	13.1	1.84	14.0	1.99	14.9	2.14	16.7	2.43	17.0	2.41		
	18	9.45	1.30	11.3	1.58	13.1	1.88	14.0	2.03	14.9	2.19	16.4	2.51	16.8	2.53		
	20	9.45	1.33	11.3	1.62	13.1	1.94	14.0	2.13	14.9	2.24	16.2	2.64	16.6	2.66		
	21	9.45	1.34	11.3	1.63	13.1	2.01	14.0	2.21	14.9	2.43	16.1	2.70	16.4	2.72		
	23	9.45	1.38	11.3	1.74	13.1	2.15	14.0	2.37	14.9	2.60	15.9	2.82	16.2	2.84		
	25	9.45	1.47	11.3	1.86	13.1	2.30	14.0	2.54	14.9	2.79	15.6	2.94	16.0	2.97		
	27	9.45	1.56	11.3	1.98	13.1	2.46	14.0	2.71	14.9	2.98	15.4	3.07	15.8	3.09		
	29	9.45	1.67	11.3	2.12	13.1	2.62	14.0	2.90	14.9	3.16	15.2	3.19	15.5	3.22		
	31	9.45	1.77	11.3	2.26	13.1	2.80	14.0	3.09	14.6	3.29	15.0	3.32	15.3	3.34		
33	9.45	1.89	11.3	2.40	13.1	2.99	14.0	3.30	14.4	3.41	14.7	3.44	15.1	3.47			
35	9.45	2.00	11.3	2.56	13.1	3.18	14.0	3.52	14.2	3.54	14.5	3.57	14.9	3.60			
37	9.45	2.13	11.3	2.72	13.1	3.39	13.8	3.64	13.9	3.66	14.3	3.69	14.6	3.73			
39	9.45	2.26	11.3	2.90	13.1	3.61	13.5	3.77	13.7	3.79	14.1	3.82	14.4	3.85			
90% 12.60 kW (113)	10	8.50	1.09	10.1	1.31	11.8	1.55	12.6	1.67	13.4	1.79	15.1	2.05	16.7	2.31		
	12	8.50	1.10	10.1	1.33	11.8	1.57	12.6	1.70	13.4	1.83	15.1	2.09	16.7	2.35		
	14	8.50	1.12	10.1	1.36	11.8	1.60	12.6	1.73	13.4	1.86	15.1	2.13	16.7	2.40		
	16	8.50	1.14	10.1	1.38	11.8	1.63	12.6	1.76	13.4	1.90	15.1	2.17	16.7	2.44		
	18	8.50	1.16	10.1	1.41	11.8	1.67	12.6	1.80	13.4	1.94	15.1	2.21	16.4	2.51		
	20	8.50	1.18	10.1	1.44	11.8	1.70	12.6	1.84	13.4	2.01	15.1	2.28	16.2	2.63		
	21	8.50	1.20	10.1	1.45	11.8	1.73	12.6	1.90	13.4	2.08	15.1	2.46	16.1	2.70		
	23	8.50	1.22	10.1	1.51	11.8	1.85	12.6	2.03	13.4	2.23	15.1	2.64	15.9	2.82		
	25	8.50	1.28	10.1	1.61	11.8	1.98	12.6	2.18	13.4	2.38	15.1	2.83	15.6	2.94		
	27	8.50	1.37	10.1	1.72	11.8	2.11	12.6	2.32	13.4	2.55	15.1	3.03	15.4	3.07		
	29	8.50	1.45	10.1	1.83	11.8	2.25	12.6	2.48	13.4	2.72	14.9	3.17	15.2	3.19		
	31	8.50	1.55	10.1	1.95	11.8	2.40	12.6	2.65	13.4	2.90	14.7	3.29	15.0	3.31		
33	8.50	1.64	10.1	2.07	11.8	2.56	12.6	2.82	13.4	3.10	14.4	3.41	14.7	3.44			
35	8.50	1.74	10.1	2.21	11.8	2.73	12.6	3.01	13.4	3.30	14.2	3.54	14.5	3.57			
37	8.50	1.85	10.1	2.35	11.8	2.90	12.6	3.20	13.4	3.52	14.0	3.66	14.3	3.69			
39	8.50	1.96	10.1	2.49	11.8	3.09	12.6	3.41	13.4	3.75	13.7	3.79	14.0	3.82			
80% 11.20 kW (100)	10	7.56	0.96	9.02	1.15	10.5	1.36	11.2	1.46	11.9	1.57	13.4	1.79	14.8	2.01		
	12	7.56	0.98	9.02	1.17	10.5	1.38	11.2	1.49	11.9	1.60	13.4	1.82	14.8	2.05		
	14	7.56	1.00	9.02	1.19	10.5	1.41	11.2	1.51	11.9	1.63	13.4	1.86	14.8	2.09		
	16	7.56	1.01	9.02	1.22	10.5	1.43	11.2	1.54	11.9	1.66	13.4	1.89	14.8	2.13		
	18	7.56	1.03	9.02	1.24	10.5	1.46	11.2	1.57	11.9	1.69	13.4	1.93	14.8	2.17		
	20	7.56	1.05	9.02	1.26	10.5	1.49	11.2	1.60	11.9	1.72	13.4	2.00	14.8	2.33		
	21	7.56	1.06	9.02	1.27	10.5	1.50	11.2	1.62	11.9	1.76	13.4	2.07	14.8	2.41		
	23	7.56	1.08	9.02	1.30	10.5	1.58	11.2	1.73	11.9	1.88	13.4	2.22	14.8	2.58		
	25	7.56	1.11	9.02	1.38	10.5	1.68	11.2	1.84	11.9	2.01	13.4	2.37	14.8	2.77		
	27	7.56	1.18	9.02	1.47	10.5	1.79	11.2	1.97	11.9	2.15	13.4	2.54	14.8	2.96		
	29	7.56	1.26	9.02	1.57	10.5	1.91	11.2	2.10	11.9	2.29	13.4	2.71	14.8	3.16		
	31	7.56	1.33	9.02	1.67	10.5	2.04	11.2	2.24	11.9	2.45	13.4	2.89	14.6	3.29		
33	7.56	1.42	9.02	1.77	10.5	2.17	11.2	2.38	11.9	2.61	13.4	3.09	14.4	3.41			
35	7.56	1.50	9.02	1.88	10.5	2.31	11.2	2.54	11.9	2.78	13.4	3.29	14.2	3.53			
37	7.56	1.59	9.02	2.00	10.5	2.45	11.2	2.70	11.9	2.96	13.4	3.51	13.9	3.66			
39	7.56	1.69	9.02	2.12	10.5	2.61	11.2	2.87	11.9	3.15	13.4	3.73	13.7	3.78			
70% 9.80 kW (88)	10	6.61	0.85	7.89	1.01	9.16	1.17	9.80	1.26	10.4	1.35	11.7	1.54	13.0	1.73		
	12	6.61	0.86	7.89	1.02	9.16	1.19	9.80	1.28	10.4	1.38	11.7	1.56	13.0	1.76		
	14	6.61	0.87	7.89	1.04	9.16	1.22	9.80	1.31	10.4	1.40	11.7	1.59	13.0	1.79		
	16	6.61	0.89	7.89	1.06	9.16	1.24	9.80	1.33	10.4	1.43	11.7	1.62	13.0	1.83		
	18	6.61	0.90	7.89	1.08	9.16	1.26	9.80	1.36	10.4	1.45	11.7	1.66	13.0	1.86		
	20	6.61	0.92	7.89	1.10	9.16	1.28	9.80	1.38	10.4	1.48	11.7	1.69	13.0	1.92		
	21	6.61	0.93	7.89	1.11	9.16	1.30	9.80	1.40	10.4	1.50	11.7	1.71	13.0	1.98		
	23	6.61	0.94	7.89	1.13	9.16	1.32	9.80	1.44	10.4	1.57	11.7	1.84	13.0	2.12		
	25	6.61	0.96	7.89	1.17	9.16	1.41	9.80	1.54	10.4	1.67	11.7	1.96	13.0	2.27		
	27	6.61	1.01	7.89	1.25	9.16	1.50	9.80	1.64	10.4	1.79	11.7	2.09	13.0	2.43		
	29	6.61	1.08	7.89	1.32	9.16	1.60	9.80	1.75	10.4	1.90	11.7	2.23	13.0	2.59		
	31	6.61	1.14	7.89	1.41	9.16	1.70	9.80	1.86	10.4	2.03	11.7	2.38	13.0	2.77		
33	6.61	1.21	7.89	1.49	9.16	1.81	9.80	1.98	10.4	2.16	11.7	2.54	13.0	2.95			
35	6.61	1.28	7.89	1.58	9.16	1.92	9.80	2.11	10.4	2.30	11.7	2.70	13.0	3.14			
37	6.61	1.35	7.89	1.68	9.16	2.04	9.80	2.24	10.4	2.44	11.7	2.88	13.0	3.35			
39	6.61	1.43	7.89	1.78	9.16	2.17	9.80	2.38	10.4	2.60	11.7	3.06	13.0	3.57			

4TW32032-1

NOTES - ANMERKUNGEN - Σημειώσεις - NOTAS - REMARQUES - NOTE - OPMERKINGEN - примечания - NOTLAR

- The above table shows the average value of conditions which may occur.
Die obige Tabelle zeigt den Durchschnittswert der Bedingungen, die auftreten können.
Στον παραπάνω πίνακα αναγράφεται η μέση τιμή για συνθήκες που μπορεί να προκύψουν.
La tabla de arriba muestra el valor medio de condiciones que pueden ocurrir.
Le tableau ci-dessus donne la valeur moyenne pour des conditions qui peuvent survenir.
La tabella in alto mostra il valore delle condizioni medie che si possono riscontrare.
De tabel hierboven geeft de gemiddelde waarde aan van situaties die kunnen voorvallen.
Таблица расположена выше показывает среднее значение условий, которые могут наступить.
Yukarıdaki tablo meydana gelebilecek koşulların ortalama değerini göstermektedir.

6 Capacity tables

6 - 1 Cooling Capacity Tables

ERQ125AW1 Cooling

TC: Total capacity; kW; PI: Power Input; kW (Comp. + Outdoor fan motor)

Combination % kW (Capacity index)	Outdoor air temp. (°CDB)	Indoor air temp. °CWB														
		14.0 °CWB 20.0 °CDB		16.0 °CWB 23.0 °CDB		18.0 °CWB 26.0 °CDB		19.0 °CWB 27.0 °CDB		20.0 °CWB 28.0 °CDB		22.0 °CWB 30.0 °CDB		24.0 °CWB 32.0 °CDB		
		TC	PI	TC	PI	TC	PI	TC	PI	TC	PI	TC	PI	TC	PI	
60% 8.40 kW (75)	10	5.67	0.74	6.76	0.87	7.85	1.00	8.40	1.07	8.95	1.14	10.0	1.29	11.1	1.45	
	12	5.67	0.75	6.76	0.88	7.85	1.02	8.40	1.09	8.95	1.16	10.0	1.32	11.1	1.48	
	14	5.67	0.76	6.76	0.89	7.85	1.03	8.40	1.11	8.95	1.18	10.0	1.34	11.1	1.50	
	16	5.67	0.77	6.76	0.91	7.85	1.05	8.40	1.13	8.95	1.21	10.0	1.37	11.1	1.53	
	18	5.67	0.78	6.76	0.92	7.85	1.07	8.40	1.15	8.95	1.23	10.0	1.39	11.1	1.56	
	20	5.67	0.79	6.76	0.94	7.85	1.09	8.40	1.17	8.95	1.25	10.0	1.42	11.1	1.59	
	21	5.67	0.80	6.76	0.95	7.85	1.10	8.40	1.18	8.95	1.26	10.0	1.43	11.1	1.61	
	23	5.67	0.81	6.76	0.96	7.85	1.12	8.40	1.20	8.95	1.29	10.0	1.49	11.1	1.71	
	25	5.67	0.83	6.76	0.98	7.85	1.16	8.40	1.26	8.95	1.37	10.0	1.59	11.1	1.83	
	27	5.67	0.86	6.76	1.04	7.85	1.24	8.40	1.35	8.95	1.46	10.0	1.70	11.1	1.95	
	29	5.67	0.91	6.76	1.10	7.85	1.32	8.40	1.43	8.95	1.55	10.0	1.81	11.1	2.08	
	31	5.67	0.96	6.76	1.17	7.85	1.40	8.40	1.52	8.95	1.65	10.0	1.92	11.1	2.22	
	33	5.67	1.02	6.76	1.24	7.85	1.48	8.40	1.62	8.95	1.75	10.0	2.05	11.1	2.36	
	35	5.67	1.08	6.76	1.31	7.85	1.58	8.40	1.72	8.95	1.86	10.0	2.18	11.1	2.51	
	37	5.67	1.14	6.76	1.39	7.85	1.67	8.40	1.82	8.95	1.98	10.0	2.31	11.1	2.67	
	39	5.67	1.20	6.76	1.47	7.85	1.77	8.40	1.93	8.95	2.10	10.0	2.46	11.1	2.84	
	50% 7.00 kW (63)	10	4.72	0.63	5.63	0.73	6.54	0.84	7.00	0.89	7.46	0.95	8.37	1.07	9.28	1.19
		12	4.72	0.64	5.63	0.74	6.54	0.85	7.00	0.91	7.46	0.97	8.37	1.09	9.28	1.21
		14	4.72	0.65	5.63	0.75	6.54	0.87	7.00	0.92	7.46	0.98	8.37	1.10	9.28	1.23
16		4.72	0.66	5.63	0.77	6.54	0.88	7.00	0.94	7.46	1.00	8.37	1.12	9.28	1.25	
18		4.72	0.67	5.63	0.78	6.54	0.89	7.00	0.95	7.46	1.02	8.37	1.14	9.28	1.28	
20		4.72	0.68	5.63	0.79	6.54	0.91	7.00	0.97	7.46	1.03	8.37	1.16	9.28	1.30	
21		4.72	0.68	5.63	0.80	6.54	0.92	7.00	0.98	7.46	1.04	8.37	1.18	9.28	1.31	
23		4.72	0.69	5.63	0.81	6.54	0.93	7.00	1.00	7.46	1.06	8.37	1.20	9.28	1.34	
25		4.72	0.70	5.63	0.82	6.54	0.95	7.00	1.02	7.46	1.09	8.37	1.26	9.28	1.43	
27		4.72	0.71	5.63	0.85	6.54	1.00	7.00	1.08	7.46	1.16	8.37	1.34	9.28	1.53	
29		4.72	0.76	5.63	0.90	6.54	1.06	7.00	1.15	7.46	1.24	8.37	1.42	9.28	1.63	
31		4.72	0.80	5.63	0.96	6.54	1.13	7.00	1.22	7.46	1.31	8.37	1.51	9.28	1.73	
33		4.72	0.84	5.63	1.01	6.54	1.19	7.00	1.29	7.46	1.39	8.37	1.61	9.28	1.84	
35		4.72	0.89	5.63	1.07	6.54	1.26	7.00	1.37	7.46	1.48	8.37	1.71	9.28	1.95	
37		4.72	0.94	5.63	1.13	6.54	1.34	7.00	1.45	7.46	1.57	8.37	1.81	9.28	2.08	
39		4.72	0.99	5.63	1.19	6.54	1.42	7.00	1.53	7.46	1.66	8.37	1.92	9.28	2.20	

6 Capacity tables

6 - 1 Cooling Capacity Tables

ERQ200AW1 Cooling

TC: Total capacity; kW; PI: Power Input; kW (Comp. + Outdoor fan motor)

Combination % kW (Capacity index)	Outdoor air temp. (°CDB)	Indoor air temp. °CWB															
		14.0 °CWB 20.0 °CDB		16.0 °CWB 23.0 °CDB		18.0 °CWB 26.0 °CDB		19.0 °CWB 27.0 °CDB		20.0 °CWB 28.0 °CDB		22.0 °CWB 30.0 °CDB		24.0 °CWB 32.0 °CDB			
		TC	PI	TC	PI	TC	PI	TC	PI	TC	PI	TC	PI	TC	PI		
100% 22.40 kW (200)	10	15.1	1.80	18.0	2.18	20.9	2.58	22.4	2.79	23.9	3.00	26.8	3.43	28.3	3.55		
	12	15.1	1.83	18.0	2.22	20.9	2.63	22.4	2.84	23.9	3.06	26.8	3.50	28.0	3.53		
	14	15.1	1.86	18.0	2.26	20.9	2.68	22.4	2.90	23.9	3.12	26.8	3.56	27.6	3.51		
	16	15.1	1.90	18.0	2.31	20.9	2.73	22.4	2.96	23.9	3.18	26.7	3.61	27.2	3.57		
	18	15.1	1.93	18.0	2.35	20.9	2.79	22.4	3.01	23.9	3.24	26.3	3.73	26.9	3.75		
	20	15.1	1.97	18.0	2.40	20.9	2.87	22.4	3.17	23.9	3.47	26.0	3.91	26.5	3.94		
	21	15.1	1.99	18.0	2.42	20.9	2.97	22.4	3.28	23.9	3.60	25.8	4.00	26.3	4.03		
	23	15.1	2.04	18.0	2.58	20.9	3.19	22.4	3.51	23.9	3.86	25.4	4.18	25.9	4.21		
	25	15.1	2.18	18.0	2.76	20.9	3.41	22.4	3.76	23.9	4.13	25.0	4.36	25.6	4.40		
	27	15.1	2.32	18.0	2.94	20.9	3.64	22.4	4.02	23.9	4.42	24.7	4.55	25.2	4.58		
	29	15.1	2.47	18.0	3.14	20.9	3.89	22.4	4.30	23.8	4.69	24.3	4.73	24.9	4.77		
	31	15.1	2.63	18.0	3.35	20.9	4.15	22.4	4.59	23.4	4.88	23.9	4.92	24.5	4.96		
33	15.1	2.80	18.0	3.56	20.9	4.43	22.4	4.89	23.0	5.06	23.6	5.10	24.1	5.15			
35	15.1	2.97	18.0	3.79	20.9	4.72	22.4	5.22	22.7	5.24	23.2	5.29	23.8	5.34			
37	15.1	3.16	18.0	4.04	20.9	5.03	22.0	5.40	22.3	5.43	22.9	5.48	23.4	5.53			
39	15.1	3.35	18.0	4.29	20.9	5.35	21.7	5.59	21.9	5.61	22.5	5.67	23.0	5.72			
90% 20.16 kW (180)	10	13.6	1.61	16.2	1.94	18.8	2.29	20.2	2.47	21.5	2.66	24.1	3.04	26.7	3.42		
	12	13.6	1.64	16.2	1.98	18.8	2.33	20.2	2.52	21.5	2.71	24.1	3.09	26.7	3.49		
	14	13.6	1.67	16.2	2.01	18.8	2.38	20.2	2.57	21.5	2.76	24.1	3.15	26.7	3.55		
	16	13.6	1.69	16.2	2.05	18.8	2.42	20.2	2.62	21.5	2.81	24.1	3.22	26.7	3.61		
	18	13.6	1.73	16.2	2.09	18.8	2.47	20.2	2.67	21.5	2.87	24.1	3.28	26.3	3.73		
	20	13.6	1.76	16.2	2.13	18.8	2.52	20.2	2.72	21.5	2.98	24.1	3.52	25.9	3.91		
	21	13.6	1.77	16.2	2.15	18.8	2.56	20.2	2.82	21.5	3.08	24.1	3.65	25.6	4.00		
	23	13.6	1.81	16.2	2.24	18.8	2.74	20.2	3.02	21.5	3.30	24.1	3.92	25.4	4.18		
	25	13.6	1.90	16.2	2.39	18.8	2.93	20.2	3.23	21.5	3.53	24.1	4.19	25.0	4.36		
	27	13.6	2.03	16.2	2.55	18.8	3.13	20.2	3.45	21.5	3.78	24.1	4.49	24.7	4.55		
	29	13.6	2.16	16.2	2.72	18.8	3.34	20.2	3.68	21.5	4.04	23.8	4.70	24.3	4.73		
	31	13.6	2.29	16.2	2.89	18.8	3.56	20.2	3.93	21.5	4.31	23.4	4.88	23.9	4.92		
33	13.6	2.44	16.2	3.08	18.8	3.80	20.2	4.19	21.5	4.59	23.1	5.06	23.6	5.10			
35	13.6	2.59	16.2	3.27	18.8	4.04	20.2	4.46	21.5	4.90	22.7	5.25	23.2	5.29			
37	13.6	2.74	16.2	3.48	18.8	4.30	20.2	4.75	21.5	5.22	22.4	5.43	22.8	5.48			
39	13.6	2.91	16.2	3.70	18.8	4.58	20.2	5.06	21.5	5.56	22.0	5.62	22.5	5.66			
80% 17.92 kW (160)	10	12.1	1.43	14.4	1.71	16.8	2.01	17.9	2.17	19.1	2.33	21.4	2.65	23.7	2.99		
	12	12.1	1.45	14.4	1.74	16.8	2.05	17.9	2.21	19.1	2.37	21.4	2.70	23.7	3.04		
	14	12.1	1.48	14.4	1.77	16.8	2.08	17.9	2.25	19.1	2.41	21.4	2.75	23.7	3.10		
	16	12.1	1.50	14.4	1.80	16.8	2.12	17.9	2.29	19.1	2.46	21.4	2.81	23.7	3.16		
	18	12.1	1.53	14.4	1.84	16.8	2.16	17.9	2.33	19.1	2.51	21.4	2.86	23.7	3.22		
	20	12.1	1.55	14.4	1.87	16.8	2.21	17.9	2.38	19.1	2.56	21.4	2.92	23.7	3.28		
	21	12.1	1.57	14.4	1.89	16.8	2.23	17.9	2.40	19.1	2.61	21.4	3.07	23.7	3.35		
	23	12.1	1.60	14.4	1.93	16.8	2.24	17.9	2.56	19.1	2.79	21.4	3.29	23.7	3.83		
	25	12.1	1.65	14.4	2.05	16.8	2.49	17.9	2.73	19.1	2.99	21.4	3.52	23.7	4.10		
	27	12.1	1.75	14.4	2.18	16.8	2.66	17.9	2.92	19.1	3.19	21.4	3.76	23.7	4.39		
	29	12.1	1.86	14.4	2.32	16.8	2.84	17.9	3.11	19.1	3.40	21.4	4.02	23.7	4.69		
	31	12.1	1.98	14.4	2.47	16.8	3.02	17.9	3.32	19.1	3.63	21.4	4.29	23.4	4.87		
33	12.1	2.10	14.4	2.63	16.8	3.22	17.9	3.53	19.1	3.86	21.4	4.58	23.0	5.06			
35	12.1	2.23	14.4	2.79	16.8	3.42	17.9	3.76	19.1	4.12	21.4	4.88	22.7	5.24			
37	12.1	2.36	14.4	2.96	16.8	3.64	17.9	4.00	19.1	4.38	21.4	5.20	22.3	5.43			
39	12.1	2.50	14.4	3.15	16.8	3.87	17.9	4.26	19.1	4.66	21.4	5.54	21.9	5.61			
70% 15.68 kW (140)	10	10.6	1.26	12.6	1.49	14.7	1.74	15.7	1.87	16.7	2.00	18.7	2.28	20.8	2.56		
	12	10.6	1.28	12.6	1.52	14.7	1.77	15.7	1.90	16.7	2.04	18.7	2.32	20.8	2.61		
	14	10.6	1.30	12.6	1.54	14.7	1.80	15.7	1.94	16.7	2.08	18.7	2.36	20.8	2.66		
	16	10.6	1.32	12.6	1.57	14.7	1.83	15.7	1.97	16.7	2.12	18.7	2.41	20.8	2.71		
	18	10.6	1.34	12.6	1.60	14.7	1.87	15.7	2.01	16.7	2.16	18.7	2.45	20.8	2.76		
	20	10.6	1.36	12.6	1.62	14.7	1.90	15.7	2.05	16.7	2.20	18.7	2.50	20.8	2.84		
	21	10.6	1.37	12.6	1.64	14.7	1.92	15.7	2.07	16.7	2.22	18.7	2.54	20.8	2.94		
	23	10.6	1.40	12.6	1.67	14.7	1.96	15.7	2.14	16.7	2.33	18.7	2.72	20.8	3.15		
	25	10.6	1.42	12.6	1.74	14.7	2.09	15.7	2.28	16.7	2.48	18.7	2.91	20.8	3.37		
	27	10.6	1.50	12.6	1.85	14.7	2.23	15.7	2.43	16.7	2.65	18.7	3.11	20.8	3.60		
	29	10.6	1.59	12.6	1.96	14.7	2.37	15.7	2.59	16.7	2.82	18.7	3.31	20.8	3.85		
	31	10.6	1.69	12.6	2.09	14.7	2.52	15.7	2.76	16.7	3.01	18.7	3.53	20.8	4.10		
33	10.6	1.79	12.6	2.21	14.7	2.68	15.7	2.94	16.7	3.20	18.7	3.76	20.8	4.38			
35	10.6	1.90	12.6	2.35	14.7	2.85	15.7	3.12	16.7	3.40	18.7	4.01	20.8	4.66			
37	10.6	2.01	12.6	2.49	14.7	3.03	15.7	3.32	16.7	3.62	18.7	4.27	20.8	4.97			
39	10.6	2.13	12.6	2.64	14.7	3.22	15.7	3.52	16.7	3.85	18.7	4.54	20.8	5.29			

4TW32032-1

NOTES - ANMERKUNGEN - Σημειώσεις - NOTAS - REMARQUES - NOTE - OPMERKINGEN - примечания - NOTLAR

- The above table shows the average value of conditions which may occur.
Die obige Tabelle zeigt den Durchschnittswert der Bedingungen, die auftreten können.
Στον παραπάνω πίνακα αναγράφεται η μέση τιμή για συνθήκες που μπορεί να προκύψουν.
La tabla de arriba muestra el valor medio de condiciones que pueden ocurrir.
Le tableau ci-dessus donne la valeur moyenne pour des conditions qui peuvent survenir.
La tabella in alto mostra il valore delle condizioni medie che si possono riscontrare.
De tabel hierboven geeft de gemiddelde waarde aan van situaties die kunnen voorvallen.
Таблица расположенная выше показывает среднее значение условий, которые могут наступить.
Yukarıdaki tablo meydana gelebilecek koşulların ortalama değerini göstermektedir.

6 Capacity tables

6 - 1 Cooling Capacity Tables

ERQ200AW1 Cooling

TC: Total capacity; kW; PI: Power Input; kW (Comp. + Outdoor fan motor)

Combination % kW (Capacity index)	Outdoor air temp. (°CDB)	Indoor air temp. °CWB														
		14.0 °CWB 20.0 °CDB		16.0 °CWB 23.0 °CDB		18.0 °CWB 26.0 °CDB		19.0 °CWB 27.0 °CDB		20.0 °CWB 28.0 °CDB		22.0 °CWB 30.0 °CDB		24.0 °CWB 32.0 °CDB		
		TC	PI	TC	PI	TC	PI	TC	PI	TC	PI	TC	PI	TC	PI	
60% 13.44 kW (120)	10	9.1	1.09	10.8	1.28	12.6	1.48	13.4	1.59	14.3	1.70	16.1	1.92	17.8	2.15	
	12	9.1	1.11	10.8	1.30	12.6	1.51	13.4	1.62	14.3	1.73	16.1	1.95	17.8	2.19	
	14	9.1	1.12	10.8	1.32	12.6	1.53	13.4	1.64	14.3	1.76	16.1	1.99	17.8	2.23	
	16	9.1	1.14	10.8	1.34	12.6	1.56	13.4	1.67	14.3	1.79	16.1	2.03	17.8	2.27	
	18	9.1	1.16	10.8	1.37	12.6	1.59	13.4	1.70	14.3	1.82	16.1	2.06	17.8	2.32	
	20	9.1	1.18	10.8	1.39	12.6	1.62	13.4	1.73	14.3	1.86	16.1	2.10	17.8	2.36	
	21	9.1	1.19	10.8	1.40	12.6	1.63	13.4	1.75	14.3	1.87	16.1	2.12	17.8	2.39	
	23	9.1	1.21	10.8	1.43	12.6	1.66	13.4	1.78	14.3	1.91	16.1	2.21	17.8	2.54	
	25	9.1	1.23	10.8	1.45	12.6	1.73	13.4	1.87	14.3	2.03	16.1	2.36	17.8	2.71	
	27	9.1	1.27	10.8	1.54	12.6	1.84	13.4	2.00	14.3	2.16	16.1	2.51	17.8	2.89	
	29	9.1	1.35	10.8	1.63	12.6	1.95	13.4	2.12	14.3	2.30	16.1	2.68	17.8	3.09	
	31	9.1	1.43	10.8	1.73	12.6	2.07	13.4	2.26	14.3	2.45	16.1	2.85	17.8	3.29	
	33	9.1	1.51	10.8	1.84	12.6	2.20	13.4	2.40	14.3	2.60	16.1	3.03	17.8	3.50	
	35	9.1	1.59	10.8	1.95	12.6	2.34	13.4	2.54	14.3	2.76	16.1	3.23	17.8	3.73	
	37	9.1	1.69	10.8	2.06	12.6	2.48	13.4	2.70	14.3	2.93	16.1	3.43	17.8	3.97	
	39	9.1	1.78	10.8	2.18	12.6	2.63	13.4	2.86	14.3	3.11	16.1	3.64	17.8	4.22	
	50% 11.20 kW (100)	10	7.56	0.94	9.0	1.09	10.5	1.24	11.2	1.33	11.9	1.41	13.4	1.58	14.8	1.76
		12	7.56	0.95	9.0	1.10	10.5	1.26	11.2	1.35	11.9	1.43	13.4	1.61	14.8	1.79
		14	7.56	0.96	9.0	1.12	10.5	1.28	11.2	1.37	11.9	1.46	13.4	1.64	14.8	1.83
16		7.56	0.98	9.0	1.14	10.5	1.30	11.2	1.39	11.9	1.49	13.4	1.67	14.8	1.86	
18		7.56	0.99	9.0	1.15	10.5	1.32	11.2	1.41	11.9	1.51	13.4	1.70	14.8	1.89	
20		7.56	1.01	9.0	1.17	10.5	1.35	11.2	1.44	11.9	1.53	13.4	1.73	14.8	1.93	
21		7.56	1.01	9.0	1.18	10.5	1.36	11.2	1.45	11.9	1.55	13.4	1.74	14.8	1.95	
23		7.56	1.03	9.0	1.20	10.5	1.38	11.2	1.48	11.9	1.57	13.4	1.78	14.8	1.99	
25		7.56	1.04	9.0	1.22	10.5	1.41	11.2	1.51	11.9	1.62	13.4	1.87	14.8	2.13	
27		7.56	1.06	9.0	1.26	10.5	1.48	11.2	1.60	11.9	1.73	13.4	1.99	14.8	2.27	
29		7.56	1.12	9.0	1.34	10.5	1.58	11.2	1.70	11.9	1.83	13.4	2.11	14.8	2.41	
31		7.56	1.18	9.0	1.42	10.5	1.67	11.2	1.81	11.9	1.95	13.4	2.25	14.8	2.57	
33		7.56	1.25	9.0	1.50	10.5	1.77	11.2	1.91	11.9	2.07	13.4	2.38	14.8	2.73	
35		7.56	1.32	9.0	1.58	10.5	1.87	11.2	2.03	11.9	2.19	13.4	2.53	14.8	2.90	
37		7.56	1.39	9.0	1.67	10.5	1.98	11.2	2.15	11.9	2.32	13.4	2.69	14.8	3.08	
39		7.56	1.47	9.0	1.77	10.5	2.10	11.2	2.28	11.9	2.46	13.4	2.85	14.8	3.27	

6 Capacity tables

6 - 1 Cooling Capacity Tables

ERQ250AW1 Cooling

TC: Total capacity; kW; PI: Power Input; kW (Comp. + Outdoor fan motor)

Combination % kW (Capacity index)	Outdoor air temp. (°CDB)	Indoor air temp. °CWB															
		14.0 °CWB 20.0 °CDB		16.0 °CWB 23.0 °CDB		18.0 °CWB 26.0 °CDB		19.0 °CWB 27.0 °CDB		20.0 °CWB 28.0 °CDB		22.0 °CWB 30.0 °CDB		24.0 °CWB 32.0 °CDB			
		TC	PI	TC	PI	TC	PI	TC	PI	TC	PI	TC	PI	TC	PI		
100% 28.0 kW (250)	10	18.9	2.56	22.5	3.10	26.2	3.67	28.0	3.97	29.8	4.27	33.5	4.88	35.4	5.05		
	12	18.9	2.60	22.5	3.16	26.2	3.74	28.0	4.04	29.8	4.35	33.5	4.97	34.9	5.02		
	14	18.9	2.65	22.5	3.22	26.2	3.81	28.0	4.12	29.8	4.43	33.5	5.07	34.5	4.99		
	16	18.9	2.70	22.5	3.28	26.2	3.89	28.0	4.20	29.8	4.52	33.3	5.13	34.0	5.08		
	18	18.9	2.75	22.5	3.34	26.2	3.96	28.0	4.28	29.8	4.61	32.9	5.30	33.6	5.34		
	20	18.9	2.80	22.5	3.41	26.2	4.08	28.0	4.50	29.8	4.94	32.4	5.55	33.1	5.60		
	21	18.9	2.83	22.5	3.44	26.2	4.23	28.0	4.66	29.8	5.11	32.2	5.68	32.9	5.73		
	23	18.9	2.90	22.5	3.67	26.2	4.53	28.0	4.99	29.8	5.48	31.8	5.94	32.4	5.99		
	25	18.9	3.09	22.5	3.92	26.2	4.85	28.0	5.35	29.8	5.87	31.3	6.20	32.0	6.25		
	27	18.9	3.30	22.5	4.18	26.2	5.18	28.0	5.72	29.8	6.28	30.8	6.46	31.5	6.52		
	29	18.9	3.51	22.5	4.46	26.2	5.53	28.0	6.11	29.7	6.67	30.4	6.73	31.1	6.78		
	31	18.9	3.74	22.5	4.76	26.2	5.90	28.0	6.52	29.3	6.93	29.9	6.99	30.6	7.05		
90% 25.2 kW (225)	10	18.9	3.97	22.5	5.07	26.2	6.29	28.0	6.96	28.8	7.19	29.5	7.25	30.2	7.32		
	12	18.9	4.22	22.5	5.39	26.2	6.71	28.0	7.42	28.3	7.45	29.0	7.52	29.7	7.58		
	14	18.9	4.49	22.5	5.74	26.2	7.15	27.5	7.68	27.9	7.72	28.6	7.79	29.2	7.85		
	16	18.9	4.77	22.5	6.10	26.2	7.61	27.1	7.94	27.4	7.98	28.1	8.05	28.8	8.13		
	18	17.0	2.29	20.3	2.76	23.6	3.26	25.2	3.52	26.8	3.78	30.1	4.32	33.4	4.87		
	12	17.0	2.33	20.3	2.81	23.6	3.32	25.2	3.58	26.8	3.85	30.1	4.40	33.4	4.96		
	14	17.0	2.37	20.3	2.86	23.6	3.38	25.2	3.65	26.8	3.92	30.1	4.48	33.4	5.05		
	16	17.0	2.41	20.3	2.91	23.6	3.45	25.2	3.72	26.8	4.00	30.1	4.57	33.3	5.14		
	18	17.0	2.45	20.3	2.97	23.6	3.51	25.2	3.79	26.8	4.08	30.1	4.66	32.9	5.30		
	20	17.0	2.50	20.3	3.03	23.6	3.58	25.2	3.87	26.8	4.23	30.1	5.01	32.4	5.55		
	21	17.0	2.52	20.3	3.06	23.6	3.64	25.2	4.00	26.8	4.38	30.1	5.19	32.2	5.68		
	23	17.0	2.57	20.3	3.18	23.6	3.90	25.2	4.29	26.8	4.70	30.1	5.57	31.7	5.94		
80% 22.4 kW (200)	10	17.0	2.71	20.3	3.40	23.6	4.17	25.2	4.59	26.8	5.02	30.1	5.96	31.3	6.20		
	12	17.0	2.88	20.3	3.62	23.6	4.45	25.2	4.90	26.8	5.37	30.1	6.38	30.8	6.46		
	14	17.0	3.07	20.3	3.86	23.6	4.75	25.2	5.23	26.8	5.74	29.8	6.67	30.4	6.72		
	16	17.0	3.26	20.3	4.11	23.6	5.06	25.2	5.58	26.8	6.12	29.3	6.93	29.9	6.99		
	18	17.0	3.46	20.3	4.37	23.6	5.40	25.2	5.95	26.8	6.53	28.9	7.20	29.5	7.25		
	20	17.0	3.68	20.3	4.65	23.6	5.75	25.2	6.34	26.8	6.96	28.4	7.46	29.0	7.52		
	21	17.0	3.90	20.3	4.94	23.6	6.12	25.2	6.75	26.8	7.42	27.9	7.72	28.6	7.78		
	23	17.0	4.14	20.3	5.26	23.6	6.51	25.2	7.19	26.8	7.90	27.5	7.99	28.1	8.05		
	10	15.1	2.03	18.0	2.43	20.9	2.86	22.4	3.08	23.9	3.30	26.8	3.77	29.7	4.25		
	12	15.1	2.06	18.0	2.47	20.9	2.91	22.4	3.14	23.9	3.37	26.8	3.84	29.7	4.33		
	14	15.1	2.10	18.0	2.52	20.9	2.96	22.4	3.19	23.9	3.43	26.8	3.91	29.7	4.41		
	16	15.1	2.13	18.0	2.56	20.9	3.02	22.4	3.25	23.9	3.49	26.8	3.99	29.7	4.49		
18	15.1	2.17	18.0	2.61	20.9	3.08	22.4	3.32	23.9	3.56	26.8	4.07	29.7	4.58			
20	15.1	2.21	18.0	2.66	20.9	3.14	22.4	3.38	23.9	3.63	26.8	4.22	29.7	4.90			
21	15.1	2.23	18.0	2.68	20.9	3.17	22.4	3.42	23.9	3.71	26.8	4.37	29.7	5.08			
23	15.1	2.27	18.0	2.74	20.9	3.32	22.4	3.64	23.9	3.97	26.8	4.68	29.7	5.45			
25	15.1	2.34	18.0	2.91	20.9	3.55	22.4	3.89	23.9	4.24	26.8	5.01	29.7	5.83			
27	15.1	2.49	18.0	3.10	20.9	3.78	22.4	4.15	23.9	4.53	26.8	5.35	29.7	6.24			
29	15.1	2.65	18.0	3.30	20.9	4.03	22.4	4.42	23.9	4.84	26.8	5.71	29.7	6.67			
31	15.1	2.81	18.0	3.51	20.9	4.29	22.4	4.71	23.9	5.16	26.8	6.10	29.2	6.93			
33	15.1	2.99	18.0	3.73	20.9	4.57	22.4	5.02	23.9	5.49	26.8	6.50	28.8	7.19			
35	15.1	3.17	18.0	3.97	20.9	4.86	22.4	5.34	23.9	5.85	26.8	6.93	28.3	7.45			
37	15.1	3.36	18.0	4.21	20.9	5.17	22.4	5.69	23.9	6.23	26.8	7.39	27.9	7.71			
39	15.1	3.56	18.0	4.47	20.9	5.50	22.4	6.05	23.9	6.63	26.8	7.87	27.4	7.98			
70% 19.6 kW (175)	10	13.2	1.79	15.8	2.12	18.3	2.47	19.6	2.66	20.9	2.85	23.4	3.24	26.0	3.64		
	12	13.2	1.81	15.8	2.15	18.3	2.52	19.6	2.71	20.9	2.90	23.4	3.30	26.0	3.71		
	14	13.2	1.84	15.8	2.19	18.3	2.56	19.6	2.75	20.9	2.95	23.4	3.36	26.0	3.78		
	16	13.2	1.87	15.8	2.23	18.3	2.61	19.6	2.81	20.9	3.01	23.4	3.42	26.0	3.85		
	18	13.2	1.90	15.8	2.27	18.3	2.66	19.6	2.86	20.9	3.06	23.4	3.49	26.0	3.93		
	20	13.2	1.93	15.8	2.31	18.3	2.71	19.6	2.91	20.9	3.12	23.4	3.56	26.0	4.04		
	21	13.2	1.95	15.8	2.33	18.3	2.73	19.6	2.94	20.9	3.15	23.4	3.61	26.0	4.18		
	23	13.2	1.98	15.8	2.37	18.3	2.79	19.6	3.04	20.9	3.31	23.4	3.87	26.0	4.48		
	25	13.2	2.02	15.8	2.47	18.3	2.97	19.6	3.25	20.9	3.53	23.4	4.14	26.0	4.79		
	27	13.2	2.14	15.8	2.63	18.3	3.17	19.6	3.46	20.9	3.77	23.4	4.42	26.0	5.12		
	29	13.2	2.27	15.8	2.79	18.3	3.37	19.6	3.69	20.9	4.01	23.4	4.71	26.0	5.47		
	31	13.2	2.40	15.8	2.96	18.3	3.59	19.6	3.92	20.9	4.27	23.4	5.02	26.0	5.83		
33	13.2	2.55	15.8	3.15	18.3	3.82	19.6	4.17	20.9	4.55	23.4	5.35	26.0	6.22			
35	13.2	2.70	15.8	3.34	18.3	4.05	19.6	4.44	20.9	4.84	23.4	5.70	26.0	6.63			
37	13.2	2.85	15.8	3.54	18.3	4.31	19.6	4.72	20.9	5.15	23.4	6.07	26.0	7.06			
39	13.2	3.02	15.8	3.75	18.3	4.57	19.6	5.01	20.9	5.47	23.4	6.45	26.0	7.52			

4TW32032-1

NOTES - ANMERKUNGEN - Σημειώσεις - NOTAS - REMARQUES - NOTE - OPMERKINGEN - примечания - NOTLAR

- The above table shows the average value of conditions which may occur.
Die obige Tabelle zeigt den Durchschnittswert der Bedingungen, die auftreten können.
Στον παραπάνω πίνακα αναγράφεται η μέση τιμή για συνθήκες που μπορεί να προκύψουν.
La tabla de arriba muestra el valor medio de condiciones que pueden ocurrir.
Le tableau ci-dessus donne la valeur moyenne pour des conditions qui peuvent survenir.
La tabella in alto mostra il valore delle condizioni medie che si possono riscontrare.
De tabel hierboven geeft de gemiddelde waarde aan van situaties die kunnen voorvallen.
Таблица расположенная выше показывает среднее значение условий, которые могут наступить.
Yukarıdaki tablo meydana gelebilecek koşulların ortalama değerini göstermektedir.

6 Capacity tables

6 - 1 Cooling Capacity Tables

ERQ250AW1 Cooling

TC: Total capacity; kW; PI: Power Input; kW (Comp. + Outdoor fan motor)

Combination % kW (Capacity index)	Outdoor air temp. (°CDB)	Indoor air temp. °CWB														
		14.0 °CWB 20.0 °CDB		16.0 °CWB 23.0 °CDB		18.0 °CWB 26.0 °CDB		19.0 °CWB 27.0 °CDB		20.0 °CWB 28.0 °CDB		22.0 °CWB 30.0 °CDB		24.0 °CWB 32.0 °CDB		
		TC	PI	TC	PI	TC	PI	TC	PI	TC	PI	TC	PI	TC	PI	
60% 16.80 kW (150)	10	11.3	1.55	13.5	1.82	15.7	2.11	16.8	2.26	17.9	2.41	20.1	2.73	22.3	3.06	
	12	11.3	1.58	13.5	1.85	15.7	2.15	16.8	2.30	17.9	2.45	20.1	2.78	22.3	3.11	
	14	11.3	1.60	13.5	1.88	15.7	2.18	16.8	2.34	17.9	2.50	20.1	2.83	22.3	3.17	
	16	11.3	1.62	13.5	1.91	15.7	2.22	16.8	2.38	17.9	2.54	20.1	2.88	22.3	3.23	
	18	11.3	1.65	13.5	1.94	15.7	2.26	16.8	2.42	17.9	2.59	20.1	2.93	22.3	3.29	
	20	11.3	1.67	13.5	1.98	15.7	2.30	16.8	2.47	17.9	2.64	20.1	2.99	22.3	3.36	
	21	11.3	1.69	13.5	1.99	15.7	2.32	16.8	2.49	17.9	2.66	20.1	3.02	22.3	3.39	
	23	11.3	1.71	13.5	2.03	15.7	2.36	16.8	2.54	17.9	2.71	20.1	3.14	22.3	3.61	
	25	11.3	1.74	13.5	2.06	15.7	2.45	16.8	2.66	17.9	2.88	20.1	3.35	22.3	3.85	
	27	11.3	1.81	13.5	2.19	15.7	2.61	16.8	2.84	17.9	3.07	20.1	3.57	22.3	4.11	
	29	11.3	1.91	13.5	2.32	15.7	2.78	16.8	3.02	17.9	3.27	20.1	3.81	22.3	4.39	
	31	11.3	2.03	13.5	2.46	15.7	2.95	16.8	3.21	17.9	3.48	20.1	4.05	22.3	4.67	
	33	11.3	2.14	13.5	2.61	15.7	3.13	16.8	3.41	17.9	3.70	20.1	4.31	22.3	4.98	
	35	11.3	2.27	13.5	2.77	15.7	3.32	16.8	3.62	17.9	3.93	20.1	4.59	22.3	5.30	
	37	11.3	2.40	13.5	2.93	15.7	3.52	16.8	3.84	17.9	4.17	20.1	4.88	22.3	5.64	
	39	11.3	2.53	13.5	3.10	15.7	3.73	16.8	4.07	17.9	4.43	20.1	5.18	22.3	6.00	
	50% 14.00 kW (125)	10	9.45	1.34	11.3	1.55	13.1	1.77	14.0	1.89	14.9	2.00	16.7	2.25	18.6	2.51
		12	9.45	1.35	11.3	1.57	13.1	1.80	14.0	1.91	14.9	2.04	16.7	2.29	18.6	2.55
		14	9.45	1.37	11.3	1.59	13.1	1.82	14.0	1.95	14.9	2.07	16.7	2.33	18.6	2.60
16		9.45	1.39	11.3	1.61	13.1	1.85	14.0	1.98	14.9	2.10	16.7	2.37	18.6	2.64	
18		9.45	1.41	11.3	1.64	13.1	1.88	14.0	2.01	14.9	2.14	16.7	2.41	18.6	2.69	
20		9.45	1.43	11.3	1.66	13.1	1.91	14.0	2.04	14.9	2.18	16.7	2.45	18.6	2.74	
21		9.45	1.44	11.3	1.68	13.1	1.93	14.0	2.06	14.9	2.20	16.7	2.48	18.6	2.77	
23		9.45	1.46	11.3	1.70	13.1	1.96	14.0	2.10	14.9	2.24	16.7	2.52	18.6	2.83	
25		9.45	1.48	11.3	1.73	13.1	2.00	14.0	2.14	14.9	2.31	16.7	2.65	18.6	3.02	
27		9.45	1.51	11.3	1.80	13.1	2.11	14.0	2.28	14.9	2.45	16.7	2.82	18.6	3.22	
29		9.45	1.59	11.3	1.90	13.1	2.24	14.0	2.42	14.9	2.61	16.7	3.00	18.6	3.43	
31		9.45	1.68	11.3	2.01	13.1	2.37	14.0	2.57	14.9	2.77	16.7	3.19	18.6	3.65	
33		9.45	1.78	11.3	2.13	13.1	2.52	14.0	2.72	14.9	2.94	16.7	3.39	18.6	3.88	
35		9.45	1.88	11.3	2.25	13.1	2.66	14.0	2.88	14.9	3.11	16.7	3.60	18.6	4.12	
37		9.45	1.98	11.3	2.38	13.1	2.82	14.0	3.05	14.9	3.30	16.7	3.82	18.6	4.38	
39		9.45	2.09	11.3	2.51	13.1	2.98	14.0	3.23	14.9	3.50	16.7	4.05	18.6	4.65	

6 Capacity tables

6 - 2 Heating Capacity Tables

ERQ125AW1

Heating

TC: Total capacity; kW; PI: Power Input; kW (Comp. + Outdoor fan motor)

Combination % kW (Capacity index)	Outdoor air temp.		Indoor air temp. °CWB															
			16.0		18.0		20.0		21.0		22.0		24.0					
			TC kW	PI kW	TC kW	PI kW	TC kW	PI kW	TC kW	PI kW	TC kW	PI kW	TC kW	PI kW				
100% 14.00 kW (125)	°CDB	°CWB																
	-19.8	-20.0	10.4	3.61	10.4	3.76	10.4	3.91	10.3	3.98	10.3	4.06	10.3	4.20	10.6	4.12	10.6	4.27
	-18.8	-19.0	10.7	3.69	10.7	3.84	10.7	3.98	10.7	4.05	10.6	4.12	10.6	4.27	10.9	4.12	10.9	4.38
	-16.7	-17.0	11.3	3.84	11.3	3.98	11.3	4.11	11.3	4.18	11.3	4.25	11.2	4.38	11.6	4.25	11.6	4.57
	-13.7	-15.0	12.0	3.97	11.9	4.10	11.9	4.23	11.9	4.29	11.9	4.36	11.9	4.49	12.3	4.36	12.3	4.67
	-11.8	-13.0	12.6	4.09	12.6	4.21	12.5	4.34	12.5	4.40	12.5	4.46	12.5	4.58	12.9	4.46	12.9	4.77
	-9.8	-11.0	13.2	4.20	13.2	4.32	13.2	4.43	13.2	4.49	13.1	4.55	13.1	4.66	13.5	4.55	13.5	4.84
	-9.5	-10.0	13.5	4.25	13.5	4.36	13.5	4.48	13.5	4.53	13.5	4.59	13.4	4.70	13.8	4.59	13.8	4.88
	-8.5	-9.1	13.8	4.30	13.8	4.41	13.8	4.52	13.7	4.57	13.7	4.63	13.7	4.74	14.1	4.63	14.1	4.92
	-7.0	-7.6	14.3	4.36	14.3	4.47	14.2	4.58	14.2	4.63	14.2	4.68	14.2	4.79	14.6	4.68	14.6	4.96
	-5.0	-5.6	14.9	4.45	14.9	4.55	14.9	4.65	14.8	4.70	14.8	4.76	14.8	4.87	15.2	4.76	15.2	5.04
	-3.0	-3.7	15.5	4.52	15.5	4.62	15.5	4.72	15.4	4.77	15.0	4.80	15.0	4.91	15.4	4.80	15.4	5.11
	0.0	-0.7	16.4	4.63	16.4	4.72	16.0	4.83	15.5	4.85	15.0	4.87	15.0	4.98	15.4	4.87	15.4	5.21
	3.0	2.2	17.4	4.72	17.0	4.68	16.0	4.34	15.5	4.17	15.0	4.00	15.0	4.00	15.4	4.00	15.4	4.21
	5.0	4.1	18.0	4.78	17.0	4.49	16.0	4.16	15.5	4.00	15.0	3.84	15.0	3.84	15.4	3.84	15.4	4.05
7.0	6.0	18.1	4.63	17.0	4.31	16.0	4.00	15.5	3.85	15.0	3.70	15.0	3.70	15.4	3.70	15.4	3.91	
9.0	7.9	18.1	4.45	17.0	4.15	16.0	3.85	15.5	3.71	15.0	3.56	15.0	3.56	15.4	3.56	15.4	3.77	
11.0	9.8	18.1	4.29	17.0	4.00	16.0	3.71	15.5	3.57	15.0	3.44	15.0	3.44	15.4	3.44	15.4	3.65	
13.0	11.8	18.1	4.13	17.0	3.85	16.0	3.58	15.5	3.45	15.0	3.32	15.0	3.32	15.4	3.32	15.4	3.53	
15.0	13.7	18.1	3.99	17.0	3.72	16.0	3.46	15.5	3.33	15.0	3.21	15.0	3.21	15.4	3.21	15.4	3.42	
90% 12.60 kW (113)	-19.8	-20.0	10.4	3.87	10.3	4.00	10.3	4.14	10.3	4.20	10.3	4.27	10.3	4.40	10.6	4.27	10.6	4.46
	-18.8	-19.0	10.7	3.94	10.6	4.07	10.6	4.20	10.6	4.27	10.6	4.33	10.6	4.46	10.9	4.33	10.9	4.65
	-16.7	-17.0	11.3	4.08	11.3	4.20	11.2	4.32	11.2	4.38	11.2	4.44	11.2	4.57	11.6	4.44	11.6	4.76
	-13.7	-15.0	11.9	4.20	11.9	4.31	11.9	4.43	11.9	4.49	11.8	4.54	11.8	4.66	12.2	4.54	12.2	4.85
	-11.8	-13.0	12.6	4.31	12.5	4.42	12.5	4.53	12.5	4.58	12.5	4.63	12.4	4.74	12.8	4.63	12.8	4.93
	-9.8	-11.0	13.2	4.40	13.2	4.51	13.1	4.61	13.1	4.66	13.1	4.72	13.1	4.83	13.5	4.72	13.5	5.02
	-9.5	-10.0	13.5	4.45	13.5	4.55	13.4	4.65	13.4	4.70	13.4	4.75	13.4	4.88	13.8	4.75	13.8	5.07
	-8.5	-9.1	13.8	4.49	13.7	4.59	13.7	4.69	13.7	4.74	13.7	4.80	13.6	4.91	14.0	4.80	14.0	5.16
	-7.0	-7.6	14.2	4.55	14.2	4.65	14.2	4.74	14.1	4.79	14.1	4.84	14.1	4.95	14.5	4.84	14.5	5.25
	-5.0	-5.6	14.9	4.63	14.8	4.72	14.4	4.60	13.9	4.42	13.5	4.24	13.5	4.24	13.9	4.24	13.9	4.45
	-3.0	-3.7	15.5	4.70	15.3	4.73	14.4	4.38	13.9	4.21	13.5	4.04	13.5	4.04	13.9	4.04	13.9	4.25
	0.0	-0.7	16.3	4.72	15.3	4.40	14.4	4.08	13.9	3.92	13.5	3.77	13.5	3.77	13.9	3.77	13.9	3.98
	3.0	2.2	16.3	4.42	15.3	4.12	14.4	3.82	13.9	3.68	13.5	3.53	13.5	3.53	13.9	3.53	13.9	3.74
	5.0	4.1	16.3	4.24	15.3	3.95	14.4	3.67	13.9	3.53	13.5	3.40	13.5	3.40	13.9	3.40	13.9	3.61
	7.0	6.0	16.3	4.07	15.3	3.80	14.4	3.53	13.9	3.40	13.5	3.27	13.5	3.27	13.9	3.27	13.9	3.48
9.0	7.9	16.3	3.92	15.3	3.66	14.4	3.40	13.9	3.28	13.5	3.16	13.5	3.16	13.9	3.16	13.9	3.37	
11.0	9.8	16.3	3.78	15.3	3.53	14.4	3.29	13.9	3.17	13.5	3.05	13.5	3.05	13.9	3.05	13.9	3.26	
13.0	11.8	16.3	3.65	15.3	3.41	14.4	3.17	13.9	3.06	13.5	2.94	13.5	2.94	13.9	2.94	13.9	3.15	
15.0	13.7	16.3	3.52	15.3	3.29	14.4	3.07	13.9	2.96	13.5	2.85	13.5	2.85	13.9	2.85	13.9	3.04	
80% 11.20 kW (100)	-19.8	-20.0	10.3	4.13	10.3	4.26	10.3	4.37	10.3	4.43	10.2	4.49	10.2	4.60	10.5	4.49	10.5	4.66
	-18.8	-19.0	10.6	4.20	10.6	4.31	10.6	4.43	10.6	4.48	10.6	4.54	10.6	4.66	10.9	4.54	10.9	4.83
	-16.7	-17.0	11.2	4.32	11.2	4.42	11.2	4.53	11.2	4.59	11.2	4.64	11.2	4.75	11.5	4.64	11.5	4.92
	-13.7	-15.0	11.9	4.42	11.9	4.53	11.8	4.63	11.8	4.68	11.8	4.73	11.8	4.84	12.1	4.73	12.1	4.99
	-11.8	-13.0	12.5	4.52	12.5	4.62	12.5	4.71	12.4	4.73	12.0	4.54	12.0	4.54	12.4	4.54	12.4	4.71
	-9.8	-11.0	13.1	4.61	13.1	4.70	12.8	4.63	12.4	4.45	12.0	4.27	12.0	4.27	12.4	4.27	12.4	4.44
	-9.5	-10.0	13.4	4.65	13.4	4.74	12.8	4.50	12.4	4.32	12.0	4.15	12.0	4.15	12.4	4.15	12.4	4.32
	-8.5	-9.1	13.7	4.68	13.6	4.73	12.8	4.38	12.4	4.21	12.0	4.04	12.0	4.04	12.4	4.04	12.4	4.21
	-7.0	-7.6	14.2	4.74	13.6	4.53	12.8	4.20	12.4	4.04	12.0	3.88	12.0	3.88	12.4	3.88	12.4	4.05
	-5.0	-5.6	14.4	4.62	13.6	4.30	12.8	3.99	12.4	3.84	12.0	3.69	12.0	3.69	12.4	3.69	12.4	3.86
	-3.0	-3.7	14.4	4.40	13.6	4.10	12.8	3.80	12.4	3.66	12.0	3.52	12.0	3.52	12.4	3.52	12.4	3.69
	0.0	-0.7	14.4	4.09	13.6	3.82	12.8	3.55	12.4	3.41	12.0	3.28	12.0	3.28	12.4	3.28	12.4	3.45
	3.0	2.2	14.4	3.84	13.6	3.58	12.8	3.33	12.4	3.21	12.0	3.09	12.0	3.09	12.4	3.09	12.4	3.26
	5.0	4.1	14.4	3.68	13.6	3.44	12.8	3.20	12.4	3.09	12.0	2.97	12.0	2.97	12.4	2.97	12.4	3.14
	7.0	6.0	14.4	3.55	13.6	3.31	12.8	3.09	12.4	2.97	12.0	2.86	12.0	2.86	12.4	2.86	12.4	3.03
9.0	7.9	14.4	3.42	13.6	3.19	12.8	2.98	12.4	2.87	12.0	2.77	12.0	2.77	12.4	2.77	12.4	2.94	
11.0	9.8	14.4	3.30	13.6	3.09	12.8	2.88	12.4	2.78	12.0	2.67	12.0	2.67	12.4	2.67	12.4	2.84	
13.0	11.8	14.4	3.18	13.6	2.98	12.8	2.78	12.4	2.68	12.0	2.59	12.0	2.59	12.4	2.59	12.4	2.76	
15.0	13.7	14.4	3.08	13.6	2.88	12.8	2.69	12.4	2.60	12.0	2.51	12.0	2.51	12.4	2.51	12.4	2.68	

4TW32032-2

NOTES - ANMERKUNGEN - Σημειώσεις - NOTAS - REMARQUES - NOTE - OPMERKINGEN - примечания - NOTLAR

- is shown as reference
 - When selecting the unit models, avoid the outdoor air temperature range shown by ■
 - dient als Verweis.
 - Vermeiden Sie bei der Auswahl der Gerätemodelle den als ■ markierten Temperaturbereich der Außenluft.
 - εμφανίζεται σαν τιμή αναφοράς.
 - Κατά την επιλογή μοντέλων μονάδων, αποφύγετε την περιοχή θερμοκρασίας εξωτερικού αέρα που εμφανίζεται στο. ■
 - se muestra a modo de referencia.
 - Cuando seleccione los modelos de unidad, evite el intervalo de temperaturas del aire exterior indicado mediante ■
 - est indiqué à titre de référence.
 - Lors de la sélection des modèles d'unité, évitez la plage de température d'air extérieur repérée par ■
 - viene mostrato come riferimento.
 - Nel selezionare i modelli delle unità, non considerare i valori di temperatura dell'aria esterna indicati con il colore ■
 - wordt ter referentie opgegeven
 - Bij selectie van de modellen dient u het gemarkeerde ■ bereik voor de buitenluchttemperatuur te vermijden.
 - приведено для справки
 - При выборе моделей блоков избегайте диапазон температура наружного воздуха, показанный в ■
 - referans olarak görülmektedir.
 - Ünite modellerini seçerken, görülen dış hava sıcaklığı aralığından kaçınınız ■
- The above table shows the average value of conditions which may occur.
 - Die obige Tabelle zeigt den Durchschnittswert der Bedingungen, die auftreten können.
 - Στον παραπάνω πίνακα αναγράφεται η μέση τιμή για συνθήκες που μπορεί να προκύψουν.
 - La tabla de arriba muestra el valor medio de condiciones que pueden ocurrir.
 - Le tableau ci-dessus donne la valeur moyenne pour des conditions qui peuvent survenir.
 - La tabella in alto mostra il valore delle condizioni medie che si possono riscontrare.
 - De tabel hierboven geeft de gemiddelde waarde aan van situaties die kunnen voorvallen.
 - Таблица расположенная выше показывает среднее значение условий, которые могут наступить.
 - Yükarıdaki tablo meydana gelebilecek koşulların ortalama değerini göstermektedir.

6 Capacity tables

6 - 2 Heating Capacity Tables

ERQ125AW1

Heating

TC: Total capacity; kW; PI: Power Input; kW (Comp. + Outdoor fan motor)

Combination % kW (Capacity index)	Outdoor air temp.		Indoor air temp. °CWB															
			16.0		18.0		20.0		21.0		22.0		24.0					
			TC	PI	TC	PI	TC	PI	TC	PI	TC	PI	TC	PI				
70% 9.80 kW (88)	°CDB	°CWB																
	-19.8	-20.0	10.3	4.39	10.2	4.49	10.2	4.60	10.2	4.65	10.2	4.70	9.8	4.50				
	-18.8	-19.0	10.6	4.45	10.6	4.55	10.5	4.65	10.5	4.70	10.5	4.73	9.8	4.33				
	-16.7	-17.0	11.2	4.55	11.2	4.65	11.2	4.74	10.8	4.58	10.5	4.40	9.8	4.03				
	-13.7	-15.0	11.8	4.65	11.8	4.74	11.2	4.46	10.8	4.28	10.5	4.11	9.8	3.78				
	-11.8	-13.0	12.5	4.73	11.9	4.51	11.2	4.18	10.8	4.02	10.5	3.86	9.8	3.55				
	-9.8	-11.0	12.6	4.56	11.9	4.24	11.2	3.94	10.8	3.79	10.5	3.64	9.8	3.35				
	-9.5	-10.0	12.6	4.43	11.9	4.12	11.2	3.83	10.8	3.68	10.5	3.54	9.8	3.26				
	-8.5	-9.1	12.6	4.31	11.9	4.02	11.2	3.73	10.8	3.59	10.5	3.45	9.8	3.18				
	-7.0	-7.6	12.6	4.14	11.9	3.86	11.2	3.59	10.8	3.45	10.5	3.32	9.8	3.06				
	-5.0	-5.6	12.6	3.93	11.9	3.67	11.2	3.41	10.8	3.28	10.5	3.16	9.8	2.92				
	-3.0	-3.7	12.6	3.75	11.9	3.50	11.2	3.26	10.8	3.14	10.5	3.02	9.8	2.79				
	0.0	-0.7	12.6	3.49	11.9	3.27	11.2	3.04	10.8	2.93	10.5	2.83	9.8	2.61				
	3.0	2.2	12.6	3.28	11.9	3.07	11.2	2.86	10.8	2.76	10.5	2.66	9.8	2.47				
	5.0	4.1	12.6	3.16	11.9	2.96	11.2	2.76	10.8	2.66	10.5	2.57	9.8	2.38				
	7.0	6.0	12.6	3.04	11.9	2.85	11.2	2.66	10.8	2.57	10.5	2.48	9.8	2.30				
	9.0	7.9	12.6	2.94	11.9	2.75	11.2	2.57	10.8	2.48	10.5	2.39	9.8	2.22				
	11.0	9.8	12.6	2.84	11.9	2.66	11.2	2.49	10.8	2.40	10.5	2.32	9.8	2.15				
13.0	11.8	12.6	2.74	11.9	2.57	11.2	2.41	10.8	2.32	10.5	2.24	9.8	2.08					
15.0	13.7	12.6	2.66	11.9	2.49	11.2	2.33	10.8	2.25	10.5	2.18	9.8	2.02					
60% 8.40 kW (75)	-19.8	-20.0	10.2	4.65	10.2	4.74	9.6	4.41	9.3	4.23	9.0	4.06	8.4	3.73				
	-18.8	-19.0	10.5	4.70	10.2	4.58	9.6	4.24	9.3	4.08	9.0	3.92	8.4	3.60				
	-16.7	-17.0	10.8	4.58	10.2	4.26	9.6	3.95	9.3	3.80	9.0	3.65	8.4	3.36				
	-13.7	-15.0	10.8	4.28	10.2	3.99	9.6	3.70	9.3	3.56	9.0	3.43	8.4	3.16				
	-11.8	-13.0	10.8	4.02	10.2	3.75	9.6	3.48	9.3	3.35	9.0	3.23	8.4	2.98				
	-9.8	-11.0	10.8	3.79	10.2	3.53	9.6	3.29	9.3	3.17	9.0	3.05	8.4	2.82				
	-9.5	-10.0	10.8	3.68	10.2	3.44	9.6	3.20	9.3	3.08	9.0	2.97	8.4	2.74				
	-8.5	-9.1	10.8	3.59	10.2	3.35	9.6	3.12	9.3	3.01	9.0	2.90	8.4	2.68				
	-7.0	-7.6	10.8	3.45	10.2	3.23	9.6	3.01	9.3	2.90	9.0	2.79	8.4	2.58				
	-5.0	-5.6	10.8	3.28	10.2	3.07	9.6	2.86	9.3	2.76	9.0	2.66	8.4	2.46				
	-3.0	-3.7	10.8	3.14	10.2	2.94	9.6	2.74	9.3	2.64	9.0	2.55	8.4	2.36				
	0.0	-0.7	10.8	2.93	10.2	2.75	9.6	2.57	9.3	2.48	9.0	2.39	8.4	2.22				
	3.0	2.2	10.8	2.76	10.2	2.59	9.6	2.42	9.3	2.34	9.0	2.26	8.4	2.10				
	5.0	4.1	10.8	2.66	10.2	2.50	9.6	2.34	9.3	2.26	9.0	2.18	8.4	2.03				
	7.0	6.0	10.8	2.57	10.2	2.41	9.6	2.26	9.3	2.18	9.0	2.11	8.4	1.96				
	9.0	7.9	10.8	2.48	10.2	2.33	9.6	2.18	9.3	2.11	9.0	2.04	8.4	1.90				
	11.0	9.8	10.8	2.40	10.2	2.26	9.6	2.12	9.3	2.05	9.0	1.98	8.4	1.84				
	13.0	11.8	10.8	2.32	10.2	2.18	9.6	2.05	9.3	1.98	9.0	1.92	8.4	1.79				
15.0	13.7	10.8	2.25	10.2	2.12	9.6	1.99	9.3	1.93	9.0	1.86	8.4	1.74					
50% 7.00 kW (63)	-19.8	-20.0	9.0	4.09	8.5	3.81	8.0	3.54	7.7	3.41	7.5	3.28	7.0	3.03				
	-18.8	-19.0	9.0	3.94	8.5	3.68	8.0	3.42	7.7	3.29	7.5	3.17	7.0	2.92				
	-16.7	-17.0	9.0	3.68	8.5	3.43	8.0	3.20	7.7	3.08	7.5	2.96	7.0	2.74				
	-13.7	-15.0	9.0	3.45	8.5	3.22	8.0	3.00	7.7	2.89	7.5	2.79	7.0	2.58				
	-11.8	-13.0	9.0	3.24	8.5	3.04	8.0	2.83	7.7	2.73	7.5	2.63	7.0	2.44				
	-9.8	-11.0	9.0	3.07	8.5	2.87	8.0	2.68	7.7	2.59	7.5	2.49	7.0	2.31				
	-9.5	-10.0	9.0	2.98	8.5	2.80	8.0	2.61	7.7	2.52	7.5	2.43	7.0	2.25				
	-8.5	-9.1	9.0	2.91	8.5	2.73	8.0	2.55	7.7	2.46	7.5	2.38	7.0	2.21				
	-7.0	-7.6	9.0	2.81	8.5	2.63	8.0	2.46	7.7	2.38	7.5	2.29	7.0	2.13				
	-5.0	-5.6	9.0	2.68	8.5	2.51	8.0	2.35	7.7	2.27	7.5	2.19	7.0	2.04				
	-3.0	-3.7	9.0	2.56	8.5	2.41	8.0	2.25	7.7	2.18	7.5	2.10	7.0	1.96				
	0.0	-0.7	9.0	2.40	8.5	2.26	8.0	2.12	7.7	2.05	7.5	1.98	7.0	1.84				
	3.0	2.2	9.0	2.27	8.5	2.14	8.0	2.00	7.7	1.94	7.5	1.87	7.0	1.75				
	5.0	4.1	9.0	2.19	8.5	2.06	8.0	1.94	7.7	1.87	7.5	1.81	7.0	1.69				
	7.0	6.0	9.0	2.12	8.5	1.99	8.0	1.87	7.7	1.81	7.5	1.76	7.0	1.64				
	9.0	7.9	9.0	2.05	8.5	1.93	8.0	1.82	7.7	1.76	7.5	1.70	7.0	1.59				
	11.0	9.8	9.0	1.99	8.5	1.87	8.0	1.76	7.7	1.71	7.5	1.65	7.0	1.55				
	13.0	11.8	9.0	1.93	8.5	1.82	8.0	1.71	7.7	1.66	7.5	1.60	7.0	1.50				
15.0	13.7	9.0	1.87	8.5	1.77	8.0	1.66	7.7	1.61	7.5	1.56	7.0	1.46					

4TW32032-2

6 Capacity tables

6 - 2 Heating Capacity Tables

ERQ200AW1

Heating

TC: Total capacity; kW; PI: Power Input; kW (Comp. + Outdoor fan motor)

Combination % kW (Capacity index)	Outdoor air temp. °CDB °CWB		Indoor air temp. °CWB																																																																																																																																																																																																																																																																									
			16.0		18.0		20.0		21.0		22.0		24.0																																																																																																																																																																																																																																																															
			TC kW	PI kW	TC kW	PI kW	TC kW	PI kW	TC kW	PI kW	TC kW	PI kW	TC kW	PI kW																																																																																																																																																																																																																																																														
100% 22.40 kW (200)	-13.8	-20.0	16.0	4.84	16.0	5.05	15.9	5.26	15.9	5.36	15.9	5.46	15.8	5.67	-18.8	-19.0	16.5	4.96	16.4	5.16	16.4	5.36	16.4	5.46	16.3	5.56	16.3	5.75	-16.7	-17.0	17.4	5.16	17.4	5.35	17.4	5.54	17.3	5.63	17.3	5.73	17.3	5.92	-13.7	-15.0	18.4	5.35	18.4	5.53	18.3	5.70	18.3	5.79	18.3	5.88	18.2	6.06	-11.8	-13.0	19.4	5.51	19.3	5.68	19.3	5.85	19.3	5.94	19.2	6.02	19.2	6.19	-9.8	-11.0	20.3	5.66	20.3	5.82	20.2	5.99	20.2	6.07	20.2	6.15	20.1	6.31	-9.5	-10.0	20.8	5.73	20.8	5.89	20.7	6.05	20.7	6.13	20.7	6.20	20.6	6.36	-8.5	-9.1	21.2	5.79	21.2	5.95	21.1	6.10	21.1	6.18	21.1	6.25	21.1	6.41	-7.0	-7.6	22.0	5.89	21.9	6.04	21.9	6.19	21.8	6.26	21.8	6.33	21.8	6.48	-5.0	-5.6	22.9	6.01	22.9	6.15	22.8	6.29	22.8	6.36	22.8	6.43	21.8	6.15	-3.0	-3.7	23.8	6.11	23.8	6.25	23.7	6.38	23.7	6.45	23.4	6.39	21.8	5.86	0.0	-0.7	25.3	6.26	25.2	6.39	25.0	6.44	24.2	6.19	23.4	5.94	21.8	5.45	3.0	2.2	26.7	6.39	26.6	6.50	25.0	6.03	24.2	5.79	23.4	5.56	21.8	5.11	5.0	4.1	27.6	6.47	26.6	6.24	25.0	5.78	24.2	5.56	23.4	5.34	21.8	4.91	7.0	6.0	28.2	6.44	26.6	5.99	25.0	5.56	24.2	5.35	23.4	5.14	21.8	4.73	9.0	7.9	28.2	6.19	26.6	5.77	25.0	5.35	24.2	5.15	23.4	4.95	21.8	4.56	11.0	9.8	28.2	5.96	26.6	5.56	25.0	5.16	24.2	4.97	23.4	4.78	21.8	4.40	13.0	11.8	28.2	5.74	26.6	5.35	25.0	4.98	24.2	4.79	23.4	4.61	21.8	4.25	15.0	13.7	28.2	5.55	26.6	5.17	25.0	4.81	24.2	4.63	23.4	4.46	21.8	4.11		
	90% 20.16 kW (180)	-19.8	-20.0	15.9	5.21	15.9	5.39	15.8	5.58	15.8	5.67	15.8	5.76	15.8	5.85	-18.8	-19.0	16.4	5.31	16.4	5.49	16.3	5.67	16.3	5.76	16.3	5.85	16.2	6.03	-16.7	-17.0	17.4	5.49	17.3	5.66	17.3	5.83	17.3	5.92	17.2	6.00	17.2	6.17	-13.7	-15.0	18.3	5.66	18.3	5.82	18.2	5.98	18.2	6.06	18.2	6.14	18.2	6.30	-11.8	-13.0	19.3	5.81	19.2	5.96	19.2	6.11	19.2	6.19	19.2	6.27	19.1	6.42	-9.8	-11.0	20.2	5.95	20.2	6.09	20.2	6.24	20.1	6.31	20.1	6.38	19.6	6.28	-9.5	-10.0	20.7	6.01	20.7	6.15	20.6	6.29	20.6	6.36	20.6	6.43	19.6	6.10	-8.5	-9.1	21.2	6.06	21.1	6.20	21.1	6.34	21.1	6.41	21.0	6.48	19.6	5.95	-7.0	-7.6	21.9	6.15	21.8	6.28	21.8	6.42	21.8	6.48	21.1	6.22	19.6	5.71	-5.0	-5.6	22.8	6.26	22.8	6.38	22.5	6.39	21.8	6.14	21.1	5.90	19.6	5.41	-3.0	-3.7	23.8	6.35	23.7	6.47	22.5	6.09	21.8	5.85	21.1	5.62	19.6	5.17	0.0	-0.7	25.2	6.49	23.9	6.11	22.5	5.67	21.8	5.45	21.1	5.24	19.6	4.82	3.0	2.2	25.4	6.14	23.9	5.72	22.5	5.31	21.8	5.11	21.1	4.91	19.6	4.53	5.0	4.1	25.4	5.89	23.9	5.49	22.5	5.10	21.8	4.91	21.1	4.72	19.6	4.35	7.0	6.0	25.4	5.66	23.9	5.28	22.5	4.91	21.8	4.73	21.1	4.55	19.6	4.20	9.0	7.9	25.4	5.45	23.9	5.09	22.5	4.73	21.8	4.56	21.1	4.39	19.6	4.05	11.0	9.8	25.4	5.26	23.9	4.91	22.5	4.57	21.8	4.40	21.1	4.24	19.6	3.91	13.0	11.8	25.4	5.07	23.9	4.73	22.5	4.41	21.8	4.25	21.1	4.09	19.6	3.78	15.0	13.7	25.4	4.90	23.9	4.58	22.5	4.27	21.8	4.11	21.1	3.96	19.6	3.66	
		80% 17.92 kW (160)	-19.8	-20.0	15.8	5.57	15.8	5.73	15.8	5.90	15.8	5.98	15.7	6.06	15.7	6.22	-18.8	-19.0	16.3	5.66	16.3	5.82	16.3	5.98	16.2	6.06	16.2	6.14	16.2	6.30	-16.7	-17.0	17.3	5.82	17.2	5.97	17.2	6.12	17.2	6.20	17.2	6.28	17.1	6.43	-13.7	-15.0	18.2	5.97	18.2	6.11	18.2	6.26	18.2	6.33	18.1	6.40	17.4	6.16	-11.8	-13.0	19.2	6.11	19.2	6.24	19.1	6.38	19.1	6.44	18.7	6.31	17.4	5.78	-9.8	-11.0	20.2	6.23	20.1	6.36	20.0	6.44	19.4	6.18	18.7	5.93	17.4	5.45	-9.5	-10.0	20.6	6.28	20.6	6.41	20.0	6.25	19.4	6.00	18.7	5.76	17.4	5.29	-8.5	-9.1	21.1	6.33	21.0	6.46	20.0	6.09	19.4	5.85	18.7	5.62	17.4	5.16	-7.0	-7.6	21.8	6.41	21.3	6.30	20.0	5.84	19.4	5.62	18.7	5.40	17.4	4.96	-5.0	-5.6	22.6	6.42	21.3	5.98	20.0	5.54	19.4	5.33	18.7	5.12	17.4	4.72	-3.0	-3.7	22.6	6.11	21.3	5.70	20.0	5.29	19.4	5.09	18.7	4.89	17.4	4.51	0.0	-0.7	22.6	5.69	21.3	5.30	20.0	4.93	19.4	4.75	18.7	4.57	17.4	4.21	3.0	2.2	22.6	5.33	21.3	4.98	20.0	4.63	19.4	4.46	18.7	4.29	17.4	3.96	5.0	4.1	22.6	5.12	21.3	4.78	20.0	4.45	19.4	4.29	18.7	4.13	17.4	3.82	7.0	6.0	22.6	4.93	21.3	4.60	20.0	4.29	19.4	4.14	18.7	3.98	17.4	3.68	9.0	7.9	22.6	4.75	21.3	4.44	20.0	4.14	19.4	3.99	18.7	3.85	17.4	3.56	11.0	9.8	22.6	4.58	21.3	4.29	20.0	4.00	19.4	3.86	18.7	3.72	17.4	3.44	13.0	11.8	22.6	4.42	21.3	4.14	20.0	3.86	19.4	3.73	18.7	3.59	17.4	3.33	15.0	13.7	22.6	4.28	21.3	4.01	20.0	3.74	19.4	3.61	18.7	3.48	17.4	3.23

4TW32032-2

NOTES - ANMERKUNGEN - Σημειώσεις - NOTAS - REMARQUES - NOTE - OPMERKINGEN - примечания - NOTLAR

- is shown as reference
 - When selecting the unit models, avoid the outdoor air temperature range shown by ■
 - dient als Verweis.
 - Vermeiden Sie bei der Auswahl der Gerätemodelle den als ■ markierten Temperaturbereich der Außenluft.
 - εμφανίζεται σαν τιμή αναφοράς.
 - Κατά την επιλογή μοντέλων μονάδων, αποφύγετε την περιοχή θερμοκρασίας εξωτερικού αέρα που εμφανίζεται στο. ■
 - se muestra a modo de referencia.
 - Cuando seleccione los modelos de unidad, evite el intervalo de temperaturas del aire exterior indicado mediante ■
 - est indiqué à titre de référence.
 - Lors de la sélection des modèles d'unité, évitez la plage de température d'air extérieur repérée par ■
 - viene mostrato come riferimento.
 - Nel selezionare i modelli delle unità, non considerare i valori di temperatura dell'aria esterna indicati con il colore ■
 - wordt ter referentie opgegeven
 - Bij selectie van de modellen dient u het gemarkeerde ■ bereik voor de buitenluchttemperatuur te vermijden.
 - приведено для справки
 - При выборе моделей блоков избегайте диапазон температура наружного воздуха, показанный в ■
 - referans olarak görülmektedir.
 - Ünite modellerini seçerken, görülen dış hava sıcaklığı aralığından kaçının ■
- The above table shows the average value of conditions which may occur.
 - Die obige Tabelle zeigt den Durchschnittswert der Bedingungen, die auftreten können.
 - Στον παραπάνω πίνακα αναγράφεται η μέση τιμή για συνθήκες που μπορεί να προκύψουν.
 - La tabla de arriba muestra el valor medio de condiciones que pueden ocurrir.
 - Le tableau ci-dessus donne la valeur moyenne pour des conditions qui peuvent survenir.
 - La tabella in alto mostra il valore delle condizioni medie che si possono riscontrare.
 - De tabel hierboven geeft de gemiddelde waarde aan van situaties die kunnen voorvallen.
 - Таблица расположенная выше показывает среднее значение условий, которые могут наступить.
 - Yükarıdaki tablo meydana gelebilecek koşulların ortalama değerini göstermektedir.

6 Capacity tables

6 - 2 Heating Capacity Tables

ERQ200AW1

Heating

TC: Total capacity; kW; PI: Power Input; kW (Comp. + Outdoor fan motor)

Combination % kW (Capacity index)	Outdoor air temp.		Indoor air temp. °CWB											
			16.0		18.0		20.0		21.0		22.0		24.0	
			TC	PI	TC	PI	TC	PI	TC	PI	TC	PI	TC	PI
	°CDB	°CWB												
70% 15.68 kW (140)	-19.8	-20.0	15.8	5.93	15.7	6.07	15.7	6.22	15.7	6.29	15.7	6.36	15.3	6.25
	-18.8	-19.0	16.2	6.01	16.2	6.15	16.2	6.29	16.2	6.36	16.2	6.43	15.3	6.02
	-16.7	-17.0	17.2	6.15	17.2	6.29	17.1	6.42	16.9	6.37	16.4	6.11	15.3	5.61
	-13.7	-15.0	18.2	6.28	18.1	6.41	17.5	6.19	16.9	5.95	16.4	5.71	15.3	5.25
	-11.8	-13.0	19.1	6.40	18.6	6.27	17.5	5.81	16.9	5.59	16.4	5.37	15.3	4.93
	-9.8	-11.0	19.7	6.34	18.6	5.90	17.5	5.47	16.9	5.27	16.4	5.06	15.3	4.66
	-9.5	-10.0	19.7	6.15	18.6	5.73	17.5	5.32	16.9	5.12	16.4	4.92	15.3	4.53
	-8.5	-9.1	19.7	6.00	18.6	5.59	17.5	5.19	16.9	4.99	16.4	4.80	15.3	4.42
	-7.0	-7.6	19.7	5.75	18.6	5.36	17.5	4.99	16.9	4.80	16.4	4.62	15.3	4.26
	-5.0	-5.6	19.7	5.46	18.6	5.09	17.5	4.74	16.9	4.56	16.4	4.39	15.3	4.05
	-3.0	-3.7	19.7	5.21	18.6	4.86	17.5	4.53	16.9	4.36	16.4	4.20	15.3	3.88
	0.0	-0.7	19.7	4.86	18.6	4.54	17.5	4.23	16.9	4.08	16.4	3.93	15.3	3.63
	3.0	2.2	19.7	4.56	18.6	4.27	17.5	3.98	16.9	3.84	16.4	3.70	15.3	3.43
	5.0	4.1	19.7	4.39	18.6	4.11	17.5	3.83	16.9	3.70	16.4	3.57	15.3	3.30
	7.0	6.0	19.7	4.23	18.6	3.96	17.5	3.70	16.9	3.57	16.4	3.44	15.3	3.19
	9.0	7.9	19.7	4.08	18.6	3.82	17.5	3.57	16.9	3.45	16.4	3.33	15.3	3.09
	11.0	9.8	19.7	3.94	18.6	3.70	17.5	3.46	16.9	3.34	16.4	3.22	15.3	2.99
13.0	11.8	19.7	3.81	18.6	3.57	17.5	3.34	16.9	3.23	16.4	3.12	15.3	2.90	
15.0	13.7	19.7	3.69	18.6	3.47	17.5	3.24	16.9	3.13	16.4	3.03	15.3	2.81	
60% 13.44 kW (120)	-19.8	-20.0	15.7	6.29	15.7	6.41	15.0	6.12	14.5	5.88	14.0	5.65	13.1	5.19
	-18.8	-19.0	16.2	6.36	16.0	6.36	15.0	5.90	14.5	5.67	14.0	5.45	13.1	5.01
	-16.7	-17.0	16.9	6.36	16.0	5.92	15.0	5.50	14.5	5.29	14.0	5.08	13.1	4.68
	-13.7	-15.0	16.9	5.95	16.0	5.54	15.0	5.15	14.5	4.95	14.0	4.76	13.1	4.39
	-11.8	-13.0	16.9	5.58	16.0	5.21	15.0	4.84	14.5	4.66	14.0	4.48	13.1	4.14
	-9.8	-11.0	16.9	5.26	16.0	4.91	15.0	4.57	14.5	4.40	14.0	4.24	13.1	3.91
	-9.5	-10.0	16.9	5.12	16.0	4.78	15.0	4.45	14.5	4.28	14.0	4.13	13.1	3.81
	-8.5	-9.1	16.9	4.99	16.0	4.66	15.0	4.34	14.5	4.18	14.0	4.03	13.1	3.72
	-7.0	-7.6	16.9	4.80	16.0	4.48	15.0	4.18	14.5	4.03	14.0	3.88	13.1	3.59
	-5.0	-5.6	16.9	4.56	16.0	4.27	15.0	3.98	14.5	3.84	14.0	3.70	13.1	3.42
	-3.0	-3.7	16.9	4.36	16.0	4.08	15.0	3.81	14.5	3.67	14.0	3.54	13.1	3.28
	0.0	-0.7	16.9	4.08	16.0	3.82	15.0	3.57	14.5	3.44	14.0	3.32	13.1	3.08
	3.0	2.2	16.9	3.84	16.0	3.60	15.0	3.37	14.5	3.25	14.0	3.14	13.1	2.92
	5.0	4.1	16.9	3.70	16.0	3.47	15.0	3.25	14.5	3.14	14.0	3.03	13.1	2.82
	7.0	6.0	16.9	3.57	16.0	3.35	15.0	3.14	14.5	3.03	14.0	2.93	13.1	2.72
	9.0	7.9	16.9	3.45	16.0	3.24	15.0	3.04	14.5	2.93	14.0	2.84	13.1	2.64
	11.0	9.8	16.9	3.34	16.0	3.14	15.0	2.94	14.5	2.84	14.0	2.75	13.1	2.56
13.0	11.8	16.9	3.23	16.0	3.04	15.0	2.85	14.5	2.76	14.0	2.66	13.1	2.48	
15.0	13.7	16.9	3.13	16.0	2.95	15.0	2.77	14.5	2.68	14.0	2.59	13.1	2.41	
50% 11.20 kW (100)	-19.8	-20.0	14.1	5.68	13.3	5.30	12.5	4.93	12.1	4.74	11.7	4.56	10.9	4.21
	-18.8	-19.0	14.1	5.48	13.3	5.11	12.5	4.76	12.1	4.58	11.7	4.40	10.9	4.06
	-16.7	-17.0	14.1	5.11	13.3	4.77	12.5	4.44	12.1	4.28	11.7	4.12	10.9	3.81
	-13.7	-15.0	14.1	4.79	13.3	4.48	12.5	4.17	12.1	4.02	11.7	3.87	10.9	3.58
	-11.8	-13.0	14.1	4.51	13.3	4.22	12.5	3.94	12.1	3.80	11.7	3.66	10.9	3.39
	-9.8	-11.0	14.1	4.26	13.3	3.99	12.5	3.73	12.1	3.60	11.7	3.47	10.9	3.21
	-9.5	-10.0	14.1	4.15	13.3	3.89	12.5	3.63	12.1	3.50	11.7	3.38	10.9	3.13
	-8.5	-9.1	14.1	4.05	13.3	3.80	12.5	3.55	12.1	3.43	11.7	3.30	10.9	3.07
	-7.0	-7.6	14.1	3.90	13.3	3.66	12.5	3.42	12.1	3.30	11.7	3.19	10.9	2.96
	-5.0	-5.6	14.1	3.72	13.3	3.49	12.5	3.26	12.1	3.15	11.7	3.05	10.9	2.83
	-3.0	-3.7	14.1	3.56	13.3	3.34	12.5	3.13	12.1	3.03	11.7	2.92	10.9	2.72
	0.0	-0.7	14.1	3.34	13.3	3.14	12.5	2.94	12.1	2.85	11.7	2.75	10.9	2.56
	3.0	2.2	14.1	3.15	13.3	2.97	12.5	2.79	12.1	2.70	11.7	2.61	10.9	2.43
	5.0	4.1	14.1	3.05	13.3	2.87	12.5	2.69	12.1	2.61	11.7	2.52	10.9	2.35
	7.0	6.0	14.1	2.94	13.3	2.77	12.5	2.61	12.1	2.52	11.7	2.44	10.9	2.28
	9.0	7.9	14.1	2.85	13.3	2.69	12.5	2.52	12.1	2.45	11.7	2.37	10.9	2.21
	11.0	9.8	14.1	2.76	13.3	2.61	12.5	2.45	12.1	2.37	11.7	2.30	10.9	2.15
13.0	11.8	14.1	2.68	13.3	2.53	12.5	2.38	12.1	2.30	11.7	2.23	10.9	2.09	
15.0	13.7	14.1	2.60	13.3	2.46	12.5	2.31	12.1	2.24	11.7	2.17	10.9	2.03	

4TW32032-2

6 Capacity tables

6 - 2 Heating Capacity Tables

ERQ250AW1

Heating

TC: Total capacity; kW; PI: Power Input; kW (Comp. + Outdoor fan motor)

Combination % kW (Capacity index)	Outdoor air temp. °CDB °CWB		Indoor air temp. °CWB																																																																																																																																																																																																																																																																									
			16.0		18.0		20.0		21.0		22.0		24.0																																																																																																																																																																																																																																																															
			TC kW	PI kW	TC kW	PI kW	TC kW	PI kW	TC kW	PI kW	TC kW	PI kW	TC kW	PI kW																																																																																																																																																																																																																																																														
70% 19.60 kW (175)	-19.8	-20.0	19.8	8.56	19.7	8.76	19.7	8.97	19.7	9.07	19.7	9.18	19.2	9.08	-18.8	-19.0	20.1	8.63	20.1	8.83	20.0	9.03	20.0	9.13	20.0	9.24	19.2	8.89	-16.7	-17.0	20.9	8.77	20.9	8.97	20.8	9.16	20.8	9.26	20.6	9.25	19.2	8.48	-13.7	-15.0	21.8	8.92	21.7	9.11	21.7	9.30	21.3	9.16	20.6	8.79	19.2	8.06	-11.8	-13.0	22.7	9.07	22.7	9.25	22.1	9.03	21.3	8.68	20.6	8.33	19.2	7.64	-9.8	-11.0	23.8	9.22	23.5	9.21	22.1	8.53	21.3	8.20	20.6	7.87	19.2	7.23	-9.5	-10.0	24.4	9.30	23.5	8.94	22.1	8.28	21.3	7.96	20.6	7.65	19.2	7.03	-8.5	-9.1	24.9	9.35	23.5	8.70	22.1	8.06	21.3	7.75	20.6	7.45	19.2	6.85	-7.0	-7.6	24.9	8.93	23.5	8.31	22.1	7.71	21.3	7.42	20.6	7.13	19.2	6.56	-5.0	-5.6	24.9	8.39	23.5	7.82	22.1	7.26	21.3	6.98	20.6	6.71	19.2	6.19	-3.0	-3.7	24.9	7.90	23.5	7.37	22.1	6.85	21.3	6.59	20.6	6.34	19.2	5.85	0.0	-0.7	24.9	7.19	23.5	6.72	22.1	6.25	21.3	6.02	20.6	5.80	19.2	5.36	3.0	2.2	24.9	6.57	23.5	6.15	22.1	5.73	21.3	5.52	20.6	5.32	19.2	4.92	5.0	4.1	24.9	6.20	23.5	5.80	22.1	5.42	21.3	5.22	20.6	5.03	19.2	4.66	7.0	6.0	24.9	5.86	23.5	5.49	22.1	5.12	21.3	4.94	20.6	4.77	19.2	4.42	9.0	7.9	24.9	5.54	23.5	5.19	22.1	4.85	21.3	4.68	20.6	4.52	19.2	4.19	11.0	9.8	24.9	5.24	23.5	4.91	22.1	4.60	21.3	4.44	20.6	4.29	19.2	3.98	13.0	11.8	24.9	4.95	23.5	4.65	22.1	4.35	21.3	4.21	20.6	4.06	19.2	3.78	15.0	13.7	24.9	4.69	23.5	4.41	22.1	4.13	21.3	4.00	20.6	3.86	19.2	3.60		
	60% 16.80 kW (150)	-19.8	-20.0	19.7	9.08	19.6	9.25	18.9	8.90	18.3	8.55	17.7	8.21	16.5	7.53	-18.8	-19.0	20.0	9.14	20.0	9.31	18.9	8.71	18.3	8.37	17.7	8.03	16.5	7.37	-16.7	-17.0	20.8	9.26	20.1	8.97	18.9	8.31	18.3	7.99	17.7	7.67	16.5	7.05	-13.7	-15.0	21.3	9.16	20.1	8.52	18.9	7.90	18.3	7.60	17.7	7.30	16.5	6.71	-11.8	-13.0	21.3	8.67	20.1	8.07	18.9	7.49	18.3	7.21	17.7	6.93	16.5	6.38	-9.8	-11.0	21.3	8.19	20.1	7.63	18.9	7.09	18.3	6.82	17.7	6.56	16.5	6.05	-9.5	-10.0	21.3	7.96	20.1	7.42	18.9	6.89	18.3	6.64	17.7	6.38	16.5	5.88	-8.5	-9.1	21.3	7.75	20.1	7.23	18.9	6.72	18.3	6.47	17.7	6.22	16.5	5.74	-7.0	-7.6	21.3	7.41	20.1	6.92	18.9	6.43	18.3	6.20	17.7	5.96	16.5	5.51	-5.0	-5.6	21.3	6.98	20.1	6.52	18.9	6.07	18.3	5.85	17.7	5.63	16.5	5.21	-3.0	-3.7	21.3	6.59	20.1	6.16	18.9	5.74	18.3	5.54	17.7	5.33	16.5	4.93	0.0	-0.7	21.3	6.02	20.1	5.64	18.9	5.26	18.3	5.08	17.7	4.89	16.5	4.53	3.0	2.2	21.3	5.52	20.1	5.18	18.9	4.84	18.3	4.67	17.7	4.51	16.5	4.18	5.0	4.1	21.3	5.22	20.1	4.90	18.9	4.58	18.3	4.43	17.7	4.27	16.5	3.97	7.0	6.0	21.3	4.94	20.1	4.64	18.9	4.34	18.3	4.20	17.7	4.06	16.5	3.77	9.0	7.9	21.3	4.68	20.1	4.40	18.9	4.12	18.3	3.99	17.7	3.85	16.5	3.59	11.0	9.8	21.3	4.44	20.1	4.18	18.9	3.92	18.3	3.79	17.7	3.66	16.5	3.42	13.0	11.8	21.3	4.20	20.1	3.96	18.9	3.72	18.3	3.60	17.7	3.48	16.5	3.25	15.0	13.7	21.3	4.00	20.1	3.76	18.9	3.54	18.3	3.43	17.7	3.32	16.5	3.10	
		50% 14.00 kW (125)	-19.8	-20.0	17.8	8.26	16.8	7.69	15.8	7.14	15.2	6.88	14.7	6.61	13.7	6.09	-18.8	-19.0	17.8	8.08	16.8	7.53	15.8	7.00	15.2	6.73	14.7	6.47	13.7	5.97	-16.7	-17.0	17.8	7.71	16.8	7.19	15.8	6.69	15.2	6.44	14.7	6.20	13.7	5.72	-13.7	-15.0	17.8	7.34	16.8	6.85	15.8	6.37	15.2	6.14	14.7	5.91	13.7	5.46	-11.8	-13.0	17.8	6.97	16.8	6.51	15.8	6.06	15.2	5.84	14.7	5.62	13.7	5.20	-9.8	-11.0	17.8	6.60	16.8	6.17	15.8	5.75	15.2	5.54	14.7	5.34	13.7	4.94	-9.5	-10.0	17.8	6.42	16.8	6.00	15.8	5.60	15.2	5.40	14.7	5.20	13.7	4.81	-8.5	-9.1	17.8	6.26	16.8	5.86	15.8	5.46	15.2	5.27	14.7	5.08	13.7	4.70	-7.0	-7.6	17.8	6.00	16.8	5.62	15.8	5.24	15.2	5.06	14.7	4.88	13.7	4.52	-5.0	-5.6	17.8	5.66	16.8	5.31	15.8	4.96	15.2	4.79	14.7	4.62	13.7	4.28	-3.0	-3.7	17.8	5.36	16.8	5.03	15.8	4.70	15.2	4.54	14.7	4.38	13.7	4.07	0.0	-0.7	17.8	4.92	16.8	4.62	15.8	4.33	15.2	4.18	14.7	4.04	13.7	3.76	3.0	2.2	17.8	4.53	16.8	4.26	15.8	3.99	15.2	3.86	14.7	3.73	13.7	3.48	5.0	4.1	17.8	4.30	16.8	4.04	15.8	3.79	15.2	3.67	14.7	3.55	13.7	3.31	7.0	6.0	17.8	4.08	16.8	3.84	15.8	3.61	15.2	3.49	14.7	3.38	13.7	3.16	9.0	7.9	17.8	3.87	16.8	3.65	15.8	3.43	15.2	3.33	14.7	3.22	13.7	3.01	11.0	9.8	17.8	3.68	16.8	3.47	15.8	3.27	15.2	3.17	14.7	3.07	13.7	2.87	13.0	11.8	17.8	3.50	16.8	3.30	15.8	3.11	15.2	3.02	14.7	2.92	13.7	2.74	15.0	13.7	17.8	3.33	16.8	3.15	15.8	2.97	15.2	2.88	14.7	2.79	13.7	2.62

4TW32032-2

NOTES - ANMERKUNGEN - Σημειώσεις - NOTAS - REMARQUES - NOTE - OPMERKINGEN - примечания - NOTLAR

- is shown as reference
 - When selecting the unit models, avoid the outdoor air temperature range shown by ■
 - dient als Verweis.
 - Vermeiden Sie bei der Auswahl der Gerätemodelle den als ■ markierten Temperaturbereich der Außenluft.
 - εμφανίζεται σαν τιμή αναφοράς.
 - Κατά την επιλογή μοντέλων μονάδων, αποφύγετε την περιοχή θερμοκρασίας εξωτερικού αέρα που εμφανίζεται στο. ■
 - se muestra a modo de referencia.
 - Cuando seleccione los modelos de unidad, evite el intervalo de temperaturas del aire exterior indicado mediante ■
 - est indiqué à titre de référence.
 - Lors de la sélection des modèles d'unité, évitez la plage de température d'air extérieur repérée par ■
 - viene mostrato come riferimento.
 - Nel selezionare i modelli delle unità, non considerare i valori di temperatura dell'aria esterna indicati con il colore ■
 - wordt ter referentie opgegeven
 - Bij selectie van de modellen dient u het gemarkeerde ■ bereik voor de buitenluchttemperatuur te vermijden.
 - приведено для справки
 - При выборе моделей блоков избегайте диапазон температура наружного воздуха, показанный в ■
 - referans olarak görülmektedir.
 - Ünite modellerini seçerken, görülen dış hava sıcaklığı aralığından kaçınin ■
- The above table shows the average value of conditions which may occur.
 - Die obige Tabelle zeigt den Durchschnittswert der Bedingungen. die auftreten können.
 - Στον παραπάνω πίνακα αναγράφεται η μέση τιμή για συνθήκες που μπορεί να προκύψουν.
 - La tabla de arriba muestra el valor medio de condiciones que pueden ocurrir.
 - Le tableau ci-dessus donne la valeur moyenne pour des conditions qui peuvent survenir.
 - La tabella in alto mostra il valore delle condizioni medie che si possono riscontrare.
 - De tabel hierboven geeft de gemiddelde waarde aan van situaties die kunnen voorvallen.
 - Таблица расположенная выше показывает среднее значение условий, которые могут наступить.
 - Yükarıdaki tablo meydana gelebilecek koşulların ortalama değerini göstermektedir.

6 Capacity tables

6 - 2 Heating Capacity Tables

ERQ250AW1

Heating

TC: Total capacity; kW; PI: Power Input; kW (Comp. + Outdoor fan motor)

Combination % kW (Capacity index)	Outdoor air temp.		Indoor air temp. °CWB											
			16.0		18.0		20.0		21.0		22.0		24.0	
	°CDB	°CWB	TC kW	PI kW	TC kW	PI kW	TC kW	PI kW	TC kW	PI kW	TC kW	PI kW	TC kW	PI kW
100% 28.00 kW (250)	-19.8	-20.0	20.1	7.00	20.0	7.29	20.0	7.59	19.9	7.74	19.9	7.88	19.8	8.18
	-18.8	-19.0	20.4	7.09	20.4	7.38	20.3	7.67	20.3	7.82	20.2	7.97	20.2	8.26
	-16.7	-17.0	21.2	7.29	21.1	7.57	21.1	7.85	21.0	7.99	21.0	8.13	21.0	8.41
	-13.7	-15.0	22.1	7.50	22.0	7.77	21.9	8.04	21.9	8.18	21.9	8.31	21.8	8.58
	-11.8	-13.0	23.0	7.72	23.0	7.97	22.9	8.23	22.9	8.36	22.9	8.49	22.8	8.75
	-9.8	-11.0	24.1	7.93	24.0	8.18	24.0	8.42	24.0	8.55	23.9	8.67	23.9	8.91
	-9.5	-10.0	24.7	8.04	24.6	8.28	24.6	8.52	24.5	8.64	24.5	8.76	24.4	9.00
	-8.5	-9.1	25.2	8.13	25.1	8.37	25.1	8.60	25.1	8.72	25.0	8.84	25.0	9.07
	-7.0	-7.6	26.1	8.29	26.1	8.52	26.0	8.74	26.0	8.86	26.0	8.97	25.9	9.20
	-5.0	-5.6	27.5	8.50	27.4	8.71	27.4	8.93	27.3	9.03	27.3	9.14	27.2	9.36
	-3.0	-3.7	28.8	8.69	28.8	8.89	28.7	9.10	28.7	9.20	28.7	9.30	27.5	8.91
	0.0	-0.7	31.1	8.97	31.1	9.16	31.0	9.35	30.5	9.20	29.5	8.82	27.5	8.09
	3.0	2.2	33.6	9.23	33.5	9.40	31.5	8.70	30.5	8.36	29.5	8.03	27.5	7.37
	5.0	4.1	35.3	9.40	33.5	8.83	31.5	8.18	30.5	7.87	29.5	7.56	27.5	6.95
	7.0	6.0	35.5	8.92	33.5	8.30	31.5	7.70	30.5	7.41	29.5	7.12	27.5	6.55
	9.0	7.9	35.5	8.38	33.5	7.81	31.5	7.25	30.5	6.98	29.5	6.71	27.5	6.18
	11.0	9.8	35.5	7.89	33.5	7.36	31.5	6.84	30.5	6.58	29.5	6.33	27.5	5.84
13.0	11.8	35.5	7.41	33.5	6.92	31.5	6.44	30.5	6.20	29.5	5.97	27.5	5.51	
15.0	13.7	35.5	6.99	33.5	6.53	31.5	6.08	30.5	5.86	29.5	5.64	27.5	5.22	
90% 25.20 kW (225)	-19.8	-20.0	20.0	7.52	19.9	7.78	19.9	8.05	19.8	8.18	19.8	8.32	19.8	8.58
	-18.8	-19.0	20.3	7.60	20.3	7.87	20.2	8.13	20.2	8.26	20.2	8.39	20.1	8.65
	-16.7	-17.0	21.1	7.79	21.0	8.04	21.0	8.29	21.0	8.42	20.9	8.54	20.9	8.79
	-13.7	-15.0	22.0	7.98	21.9	8.22	21.9	8.46	21.8	8.58	21.8	8.70	21.8	8.94
	-11.8	-13.0	22.9	8.17	22.9	8.40	22.8	8.63	22.8	8.75	22.8	8.86	22.7	9.09
	-9.8	-11.0	24.0	8.36	24.0	8.58	23.9	8.80	23.9	8.91	23.9	9.03	23.8	9.25
	-9.5	-10.0	24.6	8.46	24.5	8.68	24.5	8.89	24.4	9.00	24.4	9.11	24.4	9.32
	-8.5	-9.1	25.1	8.55	25.1	8.76	25.0	8.97	25.0	9.07	25.0	9.18	24.7	9.27
	-7.0	-7.6	26.0	8.69	26.0	8.89	25.9	9.10	25.9	9.20	25.9	9.30	24.7	8.85
	-5.0	-5.6	27.4	8.88	27.3	9.07	27.3	9.26	27.2	9.36	26.5	9.07	24.7	8.32
	-3.0	-3.7	28.7	9.05	28.7	9.23	28.4	9.27	27.4	8.90	26.5	8.54	24.7	7.84
	0.0	-0.7	31.1	9.31	30.2	9.08	28.4	8.41	27.4	8.08	26.5	7.76	24.7	7.13
	3.0	2.2	32.0	8.87	30.2	8.26	28.4	7.66	27.4	7.37	26.5	7.08	24.7	6.52
	5.0	4.1	32.0	8.34	30.2	7.77	28.4	7.22	27.4	6.94	26.5	6.68	24.7	6.15
	7.0	6.0	32.0	7.84	30.2	7.32	28.4	6.80	27.4	6.55	26.5	6.30	24.7	5.81
	9.0	7.9	32.0	7.39	30.2	6.89	28.4	6.41	27.4	6.18	26.5	5.95	24.7	5.49
	11.0	9.8	32.0	6.96	30.2	6.50	28.4	6.06	27.4	5.84	26.5	5.62	24.7	5.20
13.0	11.8	32.0	6.55	30.2	6.13	28.4	5.71	27.4	5.51	26.5	5.31	24.7	4.91	
15.0	13.7	32.0	6.19	30.2	5.79	28.4	5.41	27.4	5.22	26.5	5.03	24.7	4.66	
80% 22.40 kW (200)	-19.8	-20.0	19.9	8.04	19.8	8.27	19.8	8.51	19.8	8.63	19.7	8.75	19.7	8.98
	-18.8	-19.0	20.2	8.11	20.2	8.35	20.1	8.58	20.1	8.70	20.1	8.81	20.0	9.05
	-16.7	-17.0	21.0	8.28	20.9	8.50	20.9	8.73	20.9	8.84	20.9	8.95	20.8	9.17
	-13.7	-15.0	21.9	8.45	21.8	8.66	21.8	8.88	21.8	8.98	21.7	9.09	21.7	9.31
	-11.8	-13.0	22.8	8.62	22.8	8.83	22.7	9.03	22.7	9.13	22.7	9.24	22.0	8.99
	-9.8	-11.0	23.9	8.79	23.9	8.99	23.8	9.19	23.8	9.28	23.6	9.26	22.0	8.49
	-9.5	-10.0	24.5	8.88	24.4	9.07	24.4	9.26	24.4	9.36	23.6	8.99	22.0	8.24
	-8.5	-9.1	25.0	8.96	25.0	9.15	24.9	9.33	24.4	9.12	23.6	8.75	22.0	8.02
	-7.0	-7.6	25.9	9.09	25.9	9.27	25.2	9.07	24.4	8.71	23.6	8.36	22.0	7.67
	-5.0	-5.6	27.3	9.25	26.8	9.20	25.2	8.52	24.4	8.19	23.6	7.86	22.0	7.22
	-3.0	-3.7	28.4	9.30	26.8	8.66	25.2	8.02	24.4	7.72	23.6	7.41	22.0	6.82
	0.0	-0.7	28.4	8.44	26.8	7.86	25.2	7.30	24.4	7.03	23.6	6.75	22.0	6.22
	3.0	2.2	28.4	7.69	26.8	7.17	25.2	6.67	24.4	6.42	23.6	6.18	22.0	5.70
	5.0	4.1	28.4	7.24	26.8	6.76	25.2	6.29	24.4	6.06	23.6	5.84	22.0	5.39
	7.0	6.0	28.4	6.82	26.8	6.38	25.2	5.94	24.4	5.73	23.6	5.52	22.0	5.10
	9.0	7.9	28.4	6.44	26.8	6.02	25.2	5.61	24.4	5.41	23.6	5.22	22.0	4.83
	11.0	9.8	28.4	6.08	26.8	5.69	25.2	5.31	24.4	5.12	23.6	4.94	22.0	4.58
13.0	11.8	28.4	5.73	26.8	5.37	25.2	5.02	24.4	4.84	23.6	4.67	22.0	4.33	
15.0	13.7	28.4	5.42	26.8	5.09	25.2	4.76	24.4	4.59	23.6	4.43	22.0	4.12	

4TW32032-2

6 Capacity tables

6 - 3 Capacity Correction Factor

ERQ-AW1

Correction factor for piping length (α)
Cooling

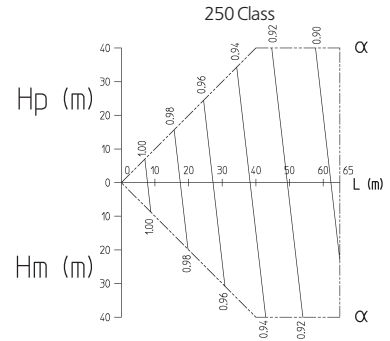
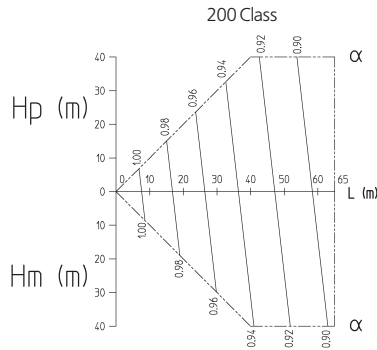
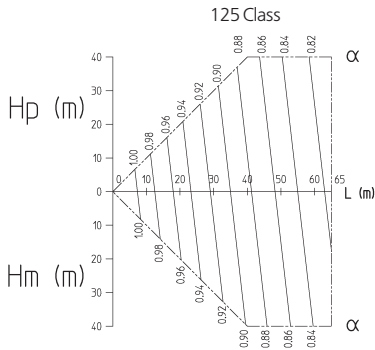

Correction factor for piping length (α)
Heating
125,200,250Class

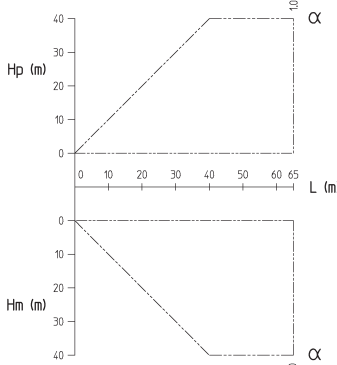

Explanation of symbols:

- Hp: Level difference between air handling unit and outdoor unit when air handling unit is installed below the outdoor unit
- Hm: Level difference between air handling unit and outdoor unit when air handling unit is installed above the outdoor unit
- L: Equivalent piping length (m)
- α: Capacity correction factor

Diameter of pipes:

Outdoor unit class	Gas	Liquid
125	φ 15.9	φ 9.5
200	φ 19.1	φ 9.5
250	φ 22.2	φ 9.5

Notes:

- 1 These figures illustrate the correction factor for piping length of the system at maximum load under standard conditions. Under partial load conditions there is only minor deviation from the correction factor shown in the figures above.
- 2 Method of calculating cooling capacity (max. capacity)
Cooling capacity = Cooling capacity obtained from the cooling capacity characteristics table X Capacity correction factor
- 3 Method of calculating heating capacity (max. capacity)
Heating capacity = Heating capacity obtained from the heating capacity characteristics table X Capacity correction factor

3TW32032-2

7 Dimensional drawings

7 - 1 Dimensional Drawings

7

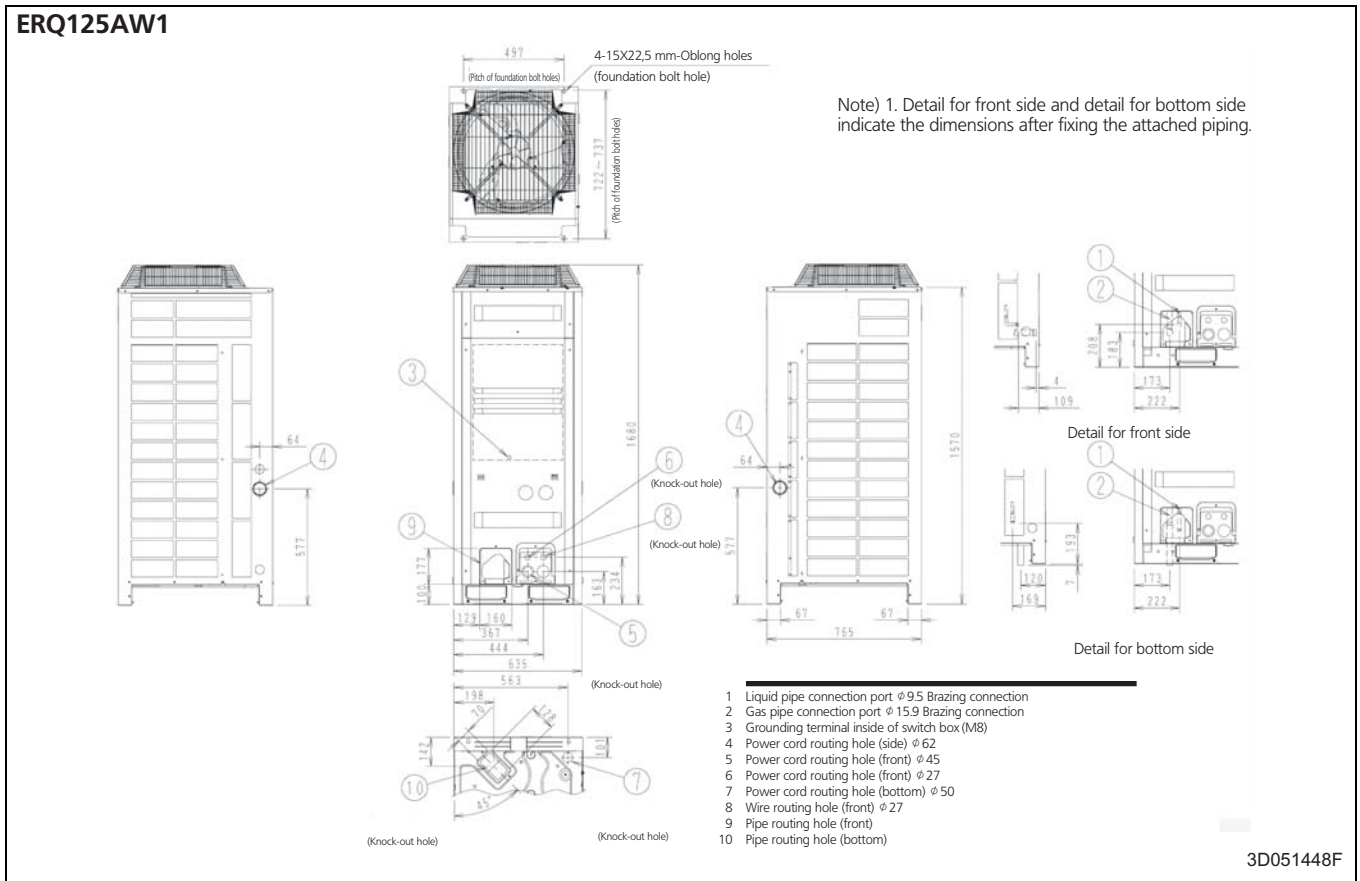
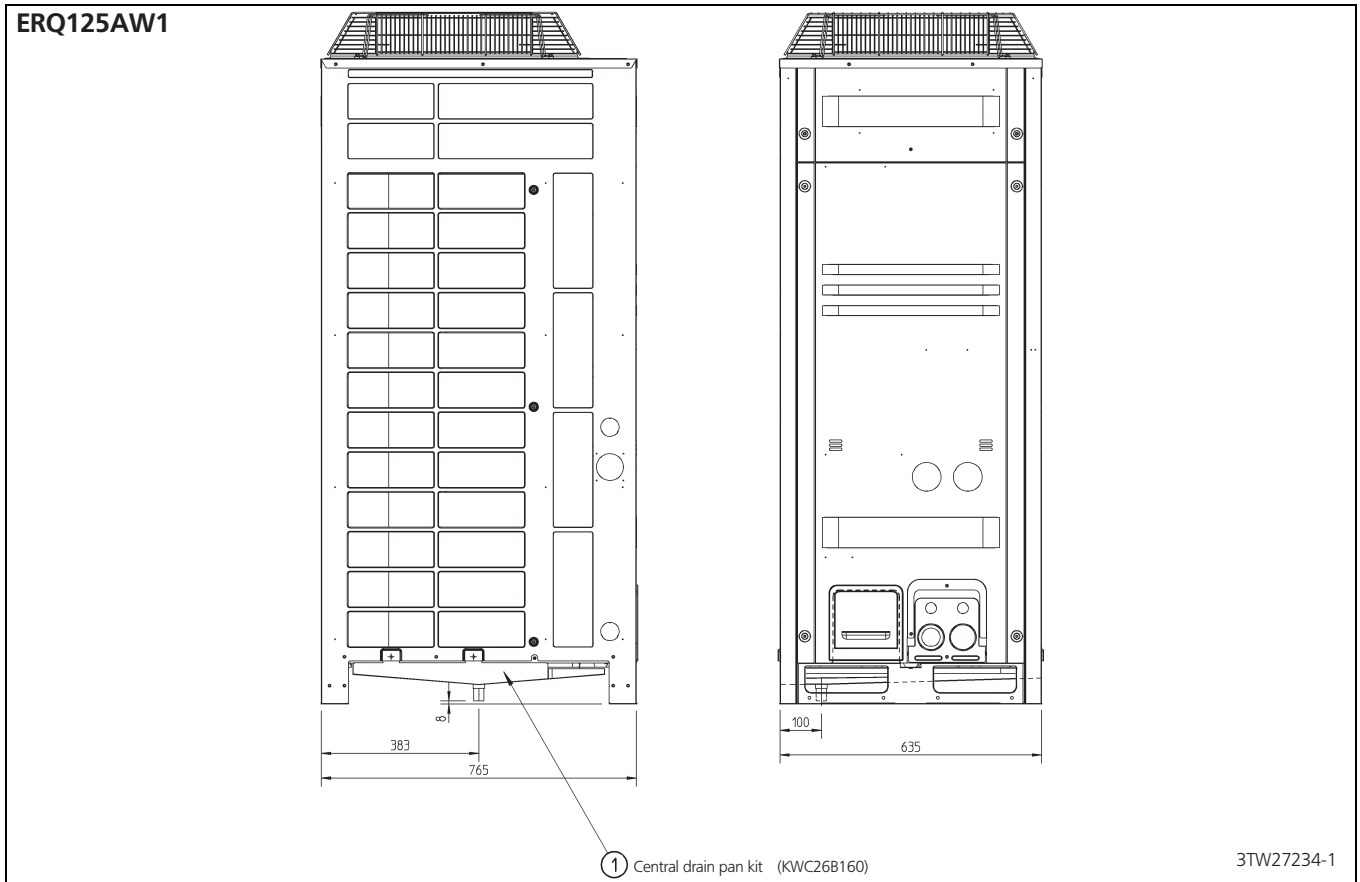

7 Dimensional drawings

7 - 1 Dimensional Drawings

ERQ200,250AW1

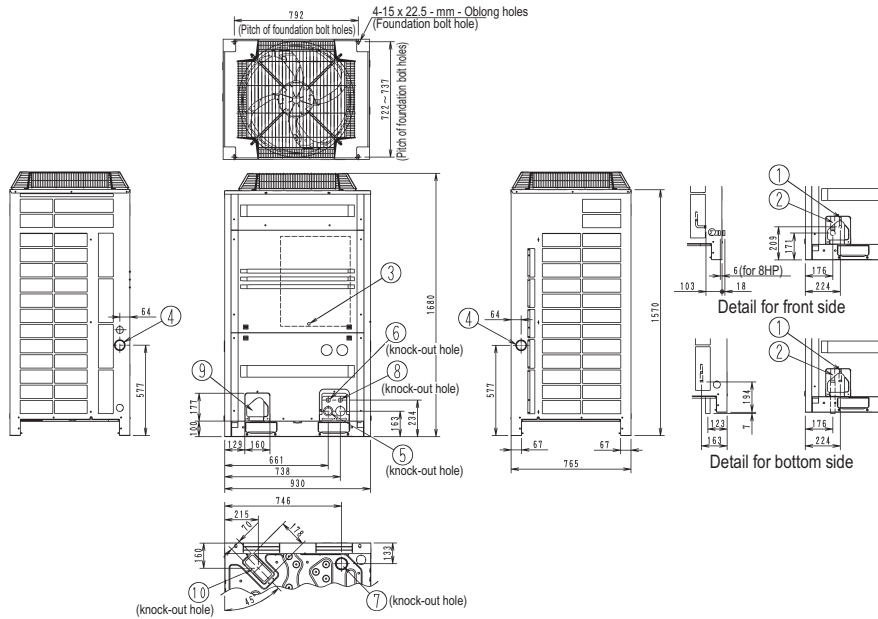

3D051449N

No.	Parts name	Remarks
1	Liquid pipe connection port	See note 2
2	Gas pipe connection port	See note 2
3	Grounding terminal	Inside of switch box (M8)
4	Power cord routing hole (side)	ø 62
5	Power cord routing hole (front)	ø 45
6	Power cord routing hole (front)	ø 27
7	Power cord routing hole (bottom)	ø 66.5
8	Wire routing hole (front)	ø 27
9	Pipe routing hole (front)	
10	Pipe routing hole (bottom)	

NOTES

- Detail for front side and detail for bottom side indicate the dimensions after fixing the attached piping.
- Gas pipe (Heat pump type)
ø 19.1 Brazing connection
ø 22.2 Brazing connection
Liquid pipe (Heat pump type)
ø 9.5 Brazing connection

ERQ200,250AW1

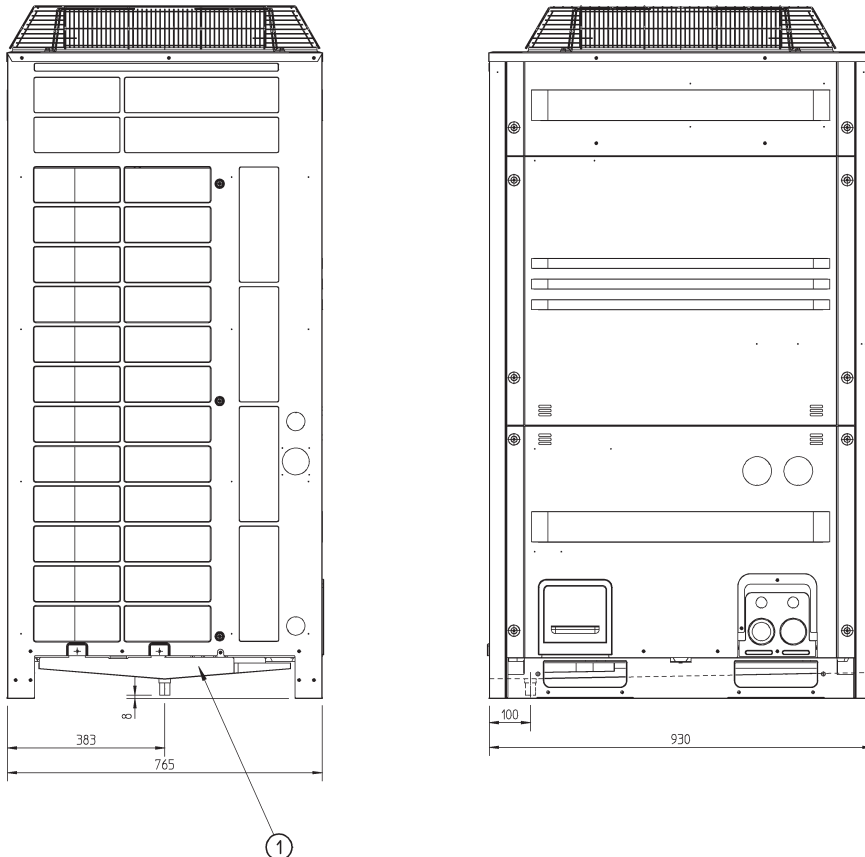

3TW27244-1

8 Centre of gravity

8 - 1 Centre of Gravity

8

ERQ125AW1

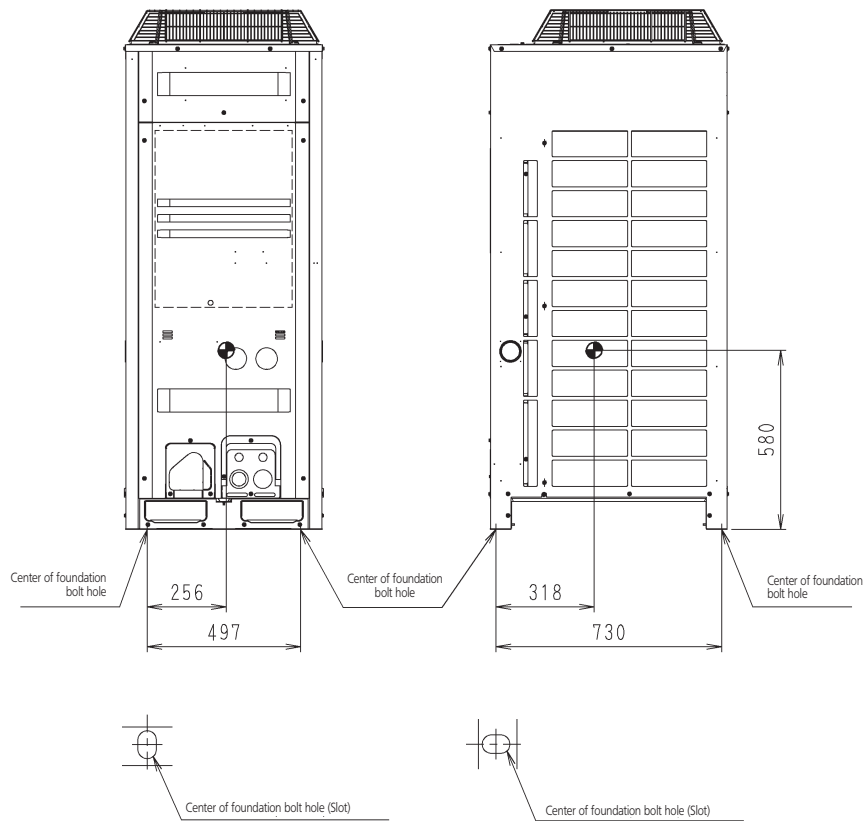

4D052145E

ERQ200AW1

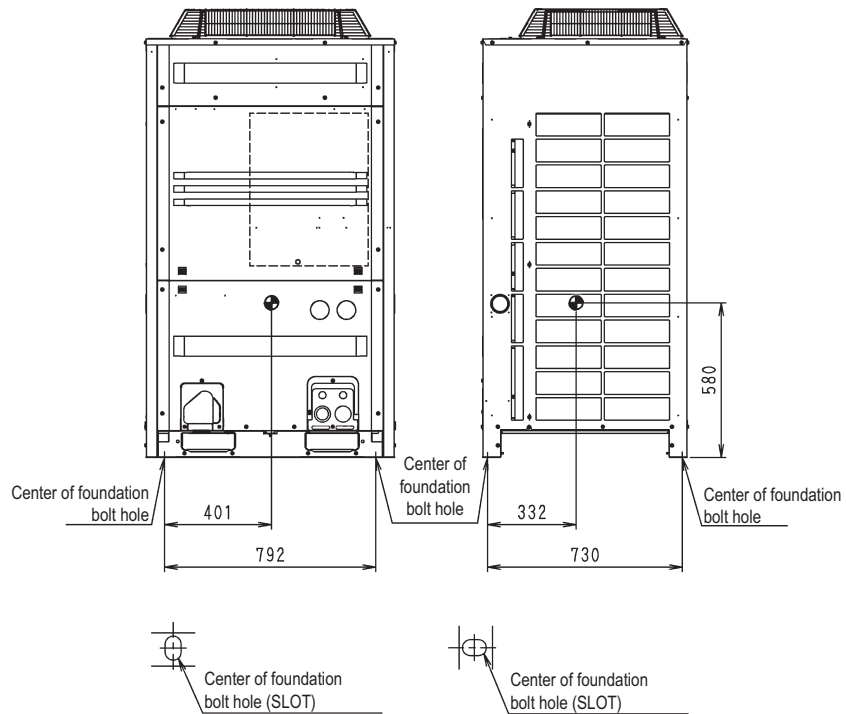

4D052146P

8 Centre of gravity

8 - 1 Centre of Gravity

ERQ250AW1

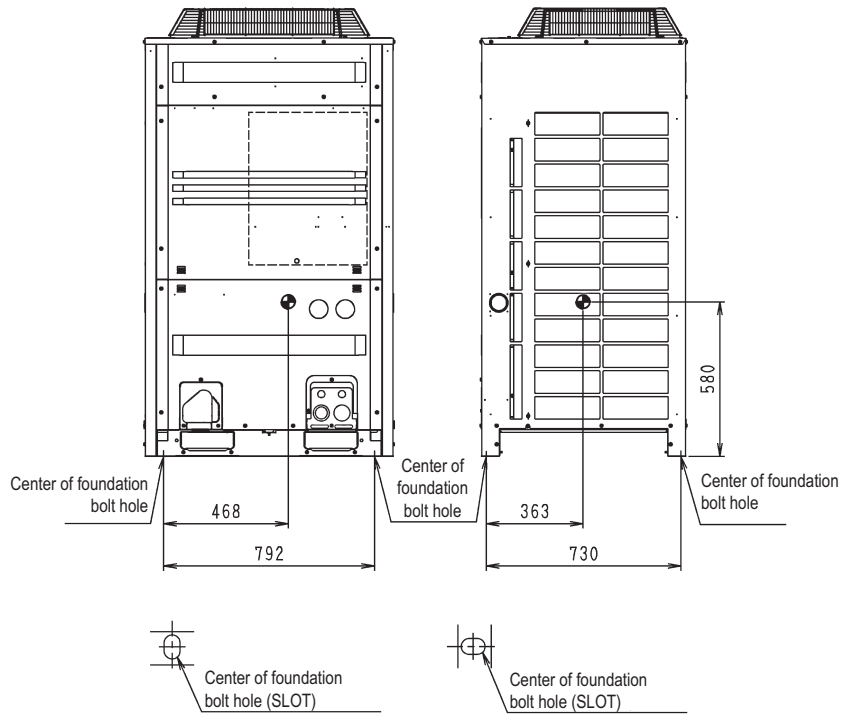

4D052147K

9 Piping diagrams

9 - 1 Piping Diagrams

9

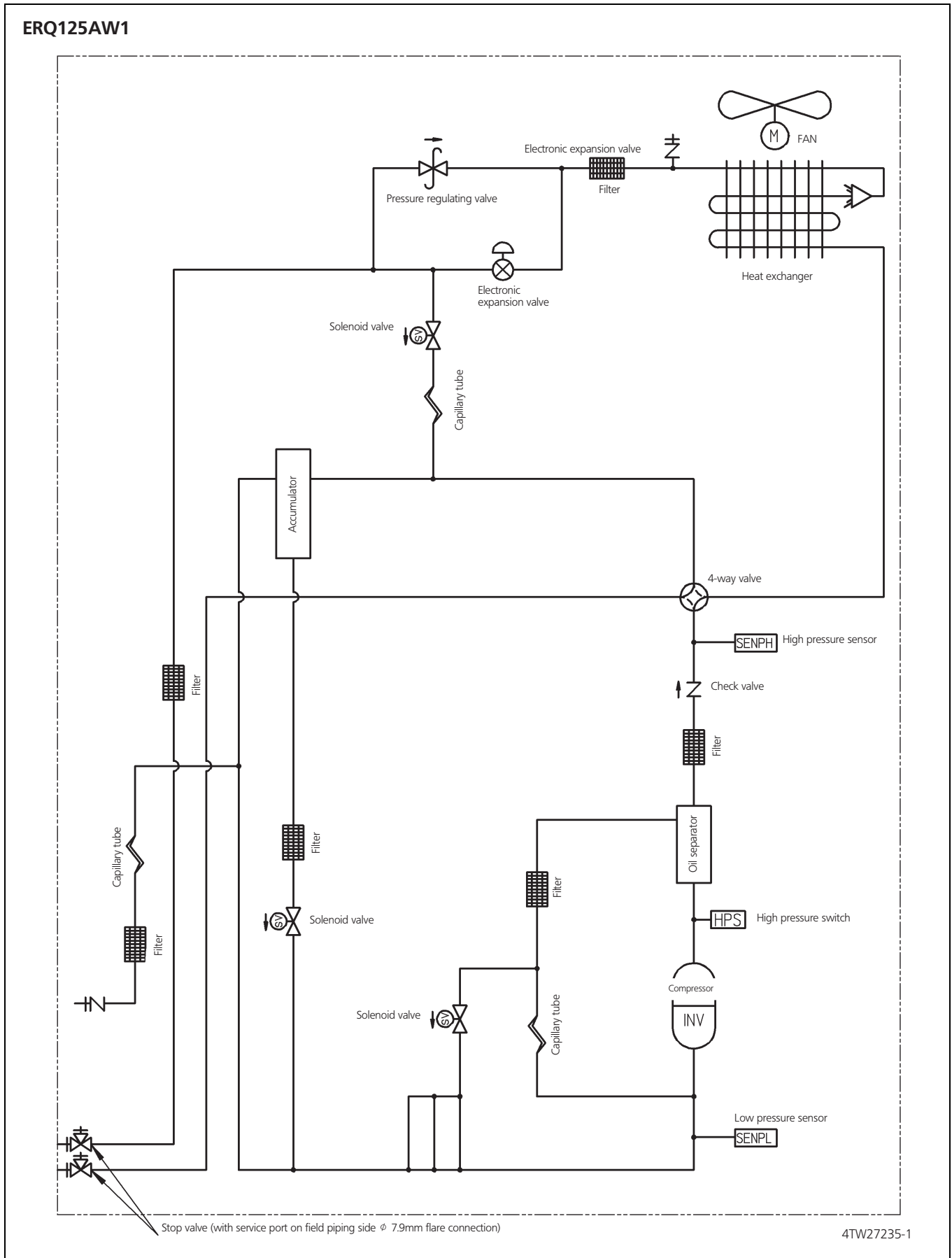

9 Piping diagrams

9 - 1 Piping Diagrams

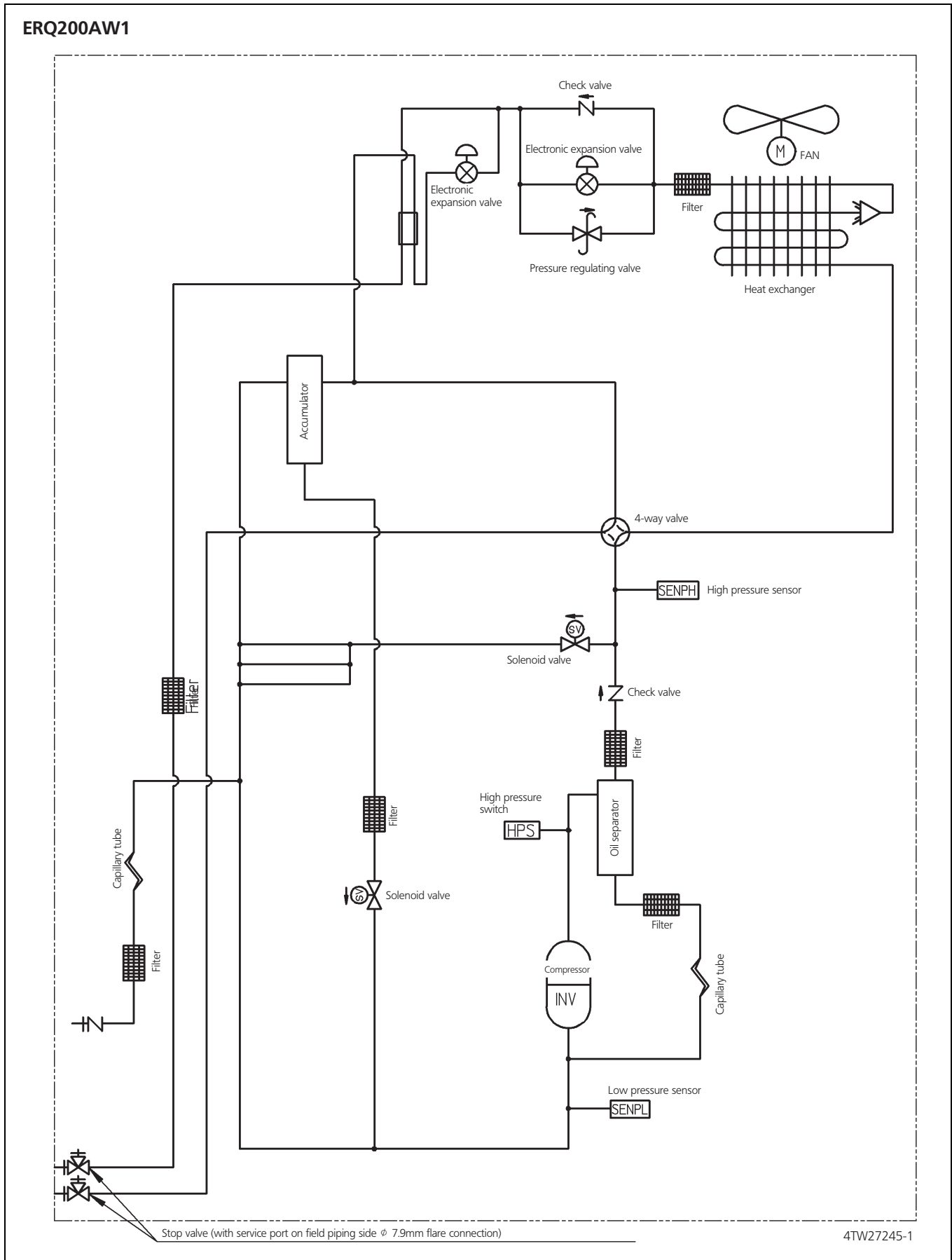

9 Piping diagrams

9 - 1 Piping Diagrams

9

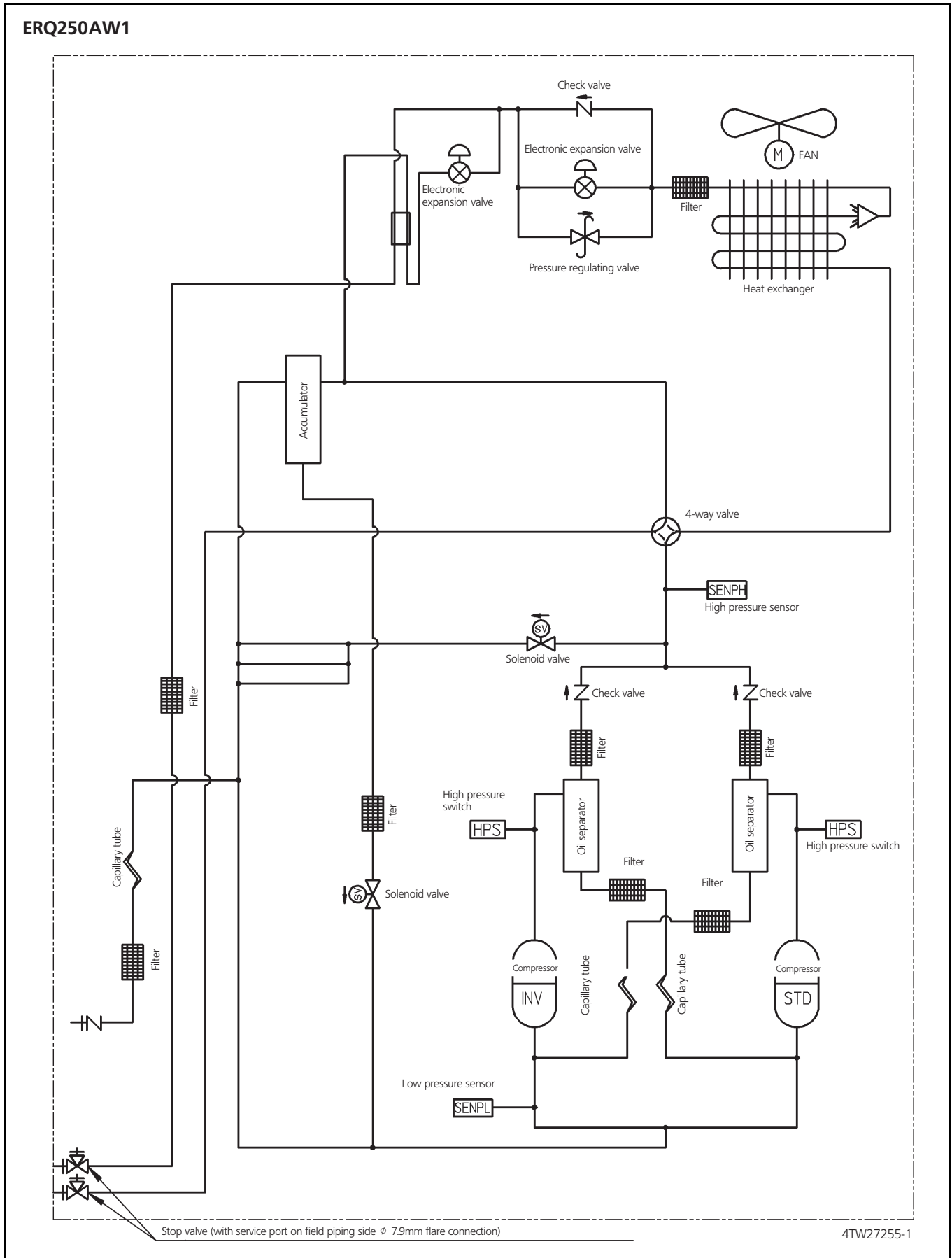

10 Wiring diagrams

10 - 1 Wiring Diagrams - Single Phase

ERQ125AW1

- A1P : Printed circuit board (Main)
- A2P : Printed circuit board (Noise filter)
- A3P : Printed circuit board (Inverter)
- A4P : Printed circuit board (Fan)
- ASP : Printed circuit board (ABC IP)
- B51-B55 : Push button switch (Mode, set, return, test, reset)
- C1 : Capacitor
- C63/C66 : Dip switch
- DS1/DS2 : Crankcase heater
- E1HC : Fuse (250V, 8A (Q)) (A4P)
- F1U : Fuse (250V, 3.15A (O)) (A1P)
- F1U/F2U : Field fuse
- F50 : Fuse (250V, 6.3A (O)) (A2P)
- H40U : Pilotlamp (service monitor - orange)
- H1P-H8P : Prepare test (Flickering)
- H2P : Multifunction detection - Light up
- H4P : Pilotlamp (service monitor - green)
- K1 : Magnetic relay
- K2 : Magnetic contactor(M1C)
- K3R : Magnetic relay (Y1S)
- K4R : Magnetic relay (Y2S)
- K5R : Magnetic relay (Y3S)
- K7R : Magnetic relay (E1HC)
- K11R : Magnetic relay (Y4S)
- L1R : Reactor
- M1C : Motor (compressor)
- M1F : Motor (fan)
- M1F : Switching power supply (A1P/A3P)
- PS : Phase reversal detect circuit
- Q1RP : Earth leakage breaker
- R10 : Resistor (Current sensor) (A4P)
- R50/R59 : Resistor
- R95 : Resistor (current limiting)
- R1T : Thermistor (air) (A1P)
- R1T : Thermistor (Fin) (A3P)
- R2T : Thermistor (Suction)
- R3T : Thermistor (discharge pipe) (M1C)
- R4T : Thermistor (Heat exch. deicer)
- R5T : Thermistor (Heat exch. deicer)
- R6T : Thermistor (liquid pipe)
- R6T : Thermistor (Accumulator)
- S1NPH : Pressure sensor (High)
- S1NPL : Pressure sensor (Low)
- S1PH : Pressure switch (High)
- SD1 : Safety devices input
- V1R : Power module (A4P)
- V1R/V2R : Connector (M1F)
- X1A/X2A : Terminal strip (Power supply)
- X1M : Terminal strip (Control) (A1P)
- X1M : Terminal strip (ASP)
- Y1E : Electronic expansion valve (Main)
- Y1S : Solenoid valve (Hot gas)
- Y2S : Solenoid valve (oil return)
- Y3S : Solenoid valve (4-way valve)
- Y4S : Solenoid valve (injection)
- Z1C-Z5C : Noise filter (ferrite core)
- Z1F : Noise filter (with surge absorber)

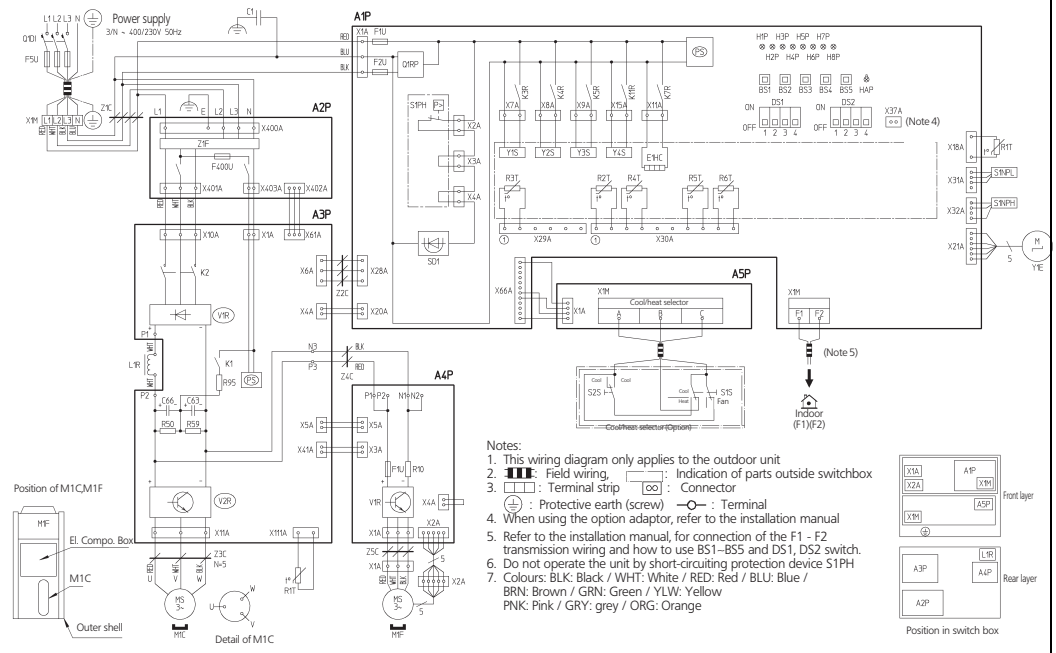

- Notes:
- This wiring diagram only applies to the outdoor unit
 - Field wiring. Indication of parts outside switch box
 - Terminal strip () Connector
 - Protective earth (screw) Terminal
 - When using the option adaptor, refer to the installation manual
 - Refer to the installation manual, for connection of the F1 - F2 transmission wiring and how to use B51-B55 and DS1, DS2 switch.
 - Do not operate the unit by short-circuiting protection device S1PH
 - Colours: BLK: Black / WHT: White / RED: Red / BLU: Blue / BRN: Brown / GRN: Green / YLW: Yellow / PNK: Pink / GRY: grey / ORG: Orange

2TW32036-1

ERQ200AW1

- A1P : Printed circuit board (Main)
- A2P : Printed circuit board (Noise filter)
- A3P : Printed circuit board (Inverter)
- A4P : Printed circuit board (Fan)
- ASP : Printed circuit board (ABC IP)
- B51-B55 : Push button switch (Mode, set, return, test, reset)
- C1 : Capacitor
- C63/C66 : Dip switch
- DS1/DS2 : Crankcase heater
- E1HC : Fuse (250V, 8A (Q)) (A4P)
- F1U : Fuse (250V, 3.15A (O)) (A1P)
- F1U/F2U : Field fuse
- F50 : Fuse (250V, 6.3A (O)) (A2P)
- H40U : Pilotlamp (service monitor - orange)
- H1P-H8P : Prepare test (Flickering)
- H2P : Multifunction detection - Light up
- H4P : Pilotlamp (service monitor - green)
- K1 : Magnetic relay
- K2 : Magnetic contactor(M1C)
- K3R : Magnetic relay (Y1S)
- K4R : Magnetic relay (Y2S)
- K5R : Magnetic relay (Y3S)
- K7R : Magnetic relay (E1HC)
- L1R : Reactor
- M1C : Motor (compressor)
- M1F : Motor (fan)
- M1F : Switching power supply (A1P/A3P)
- PS : Phase reversal detect circuit
- Q1RP : Earth leakage breaker
- R10 : Resistor (Current sensor) (A4P)
- R50/R59 : Resistor
- R95 : Resistor (current limiting)
- R1T : Thermistor (air) (A1P)
- R1T : Thermistor (Fin) (A3P)
- R2T : Thermistor (Suction)
- R3T : Thermistor (discharge pipe) (M1C)
- R4T : Thermistor (Heat exch. deicer)
- R5T : Thermistor (Heat exch. deicer)
- R6T : Thermistor (liquid pipe)
- R6T : Thermistor (Accumulator)
- S1NPH : Pressure sensor (High)
- S1NPL : Pressure sensor (Low)
- S1PH : Pressure switch (High)
- SD1 : Safety devices input
- V1R : Power module (A4P)
- V1R/V2R : Connector (M1F)
- X1A/X2A : Terminal strip (Power supply)
- X1M : Terminal strip (Control) (A1P)
- X1M : Terminal strip (ASP)
- Y1E : Electronic expansion valve (Main)
- Y1S : Solenoid valve (Hot gas)
- Y2S : Solenoid valve (oil return)
- Y3S : Solenoid valve (4-way valve)
- Y4S : Solenoid valve (injection)
- Z1C-Z5C : Noise filter (ferrite core)
- Z1F : Noise filter (with surge absorber)

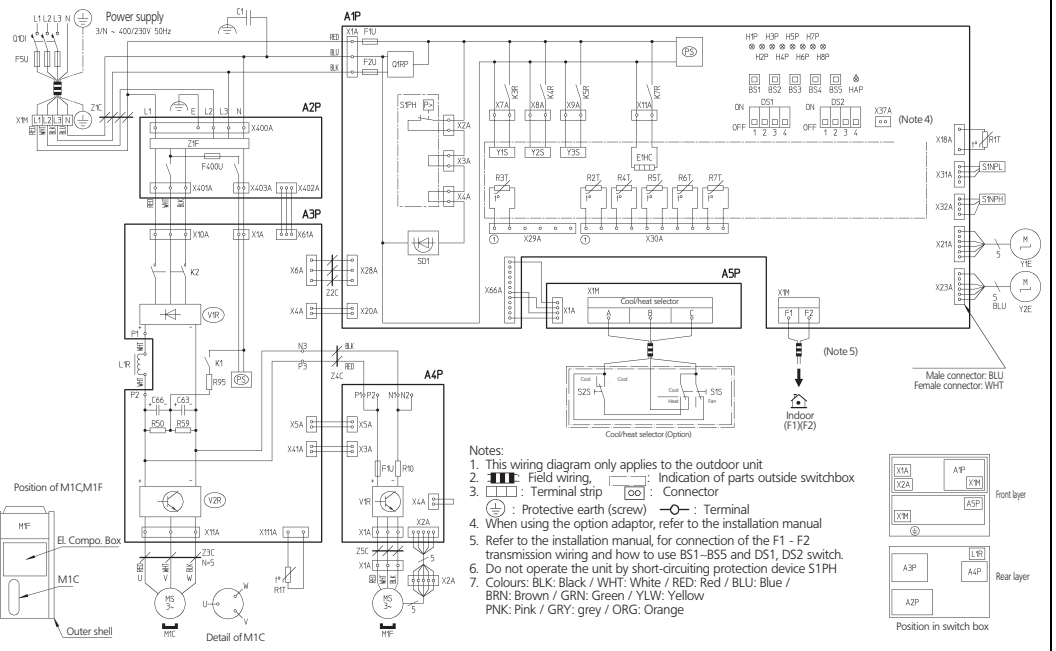

- Notes:
- This wiring diagram only applies to the outdoor unit
 - Field wiring. Indication of parts outside switch box
 - Terminal strip () Connector
 - Protective earth (screw) Terminal
 - When using the option adaptor, refer to the installation manual
 - Refer to the installation manual, for connection of the F1 - F2 transmission wiring and how to use B51-B55 and DS1, DS2 switch.
 - Do not operate the unit by short-circuiting protection device S1PH
 - Colours: BLK: Black / WHT: White / RED: Red / BLU: Blue / BRN: Brown / GRN: Green / YLW: Yellow / PNK: Pink / GRY: grey / ORG: Orange

2TW32046-1

10 Wiring diagrams

10 - 1 Wiring Diagrams - Single Phase

10

ERQ250AW1

- A1P : Printed circuit board (Main)
- A2P : Printed circuit board (Noise filter)
- A3P : Printed circuit board (Inverter)
- A4P : Printed circuit board (Fan)
- A5P : Printed circuit board (ABC (F))
- A6P : Printed circuit board (Current sensor)
- B51~B55 : Push button switch (Mode set, return, test, reset)
- C1 : Capacitor
- C63,C66 : Capacitor
- DS1,DS2 : Dip switch
- E1HC : Crankcase heater
- F1U : Fuse (250V, 8A (6)) (A4P)
- F1U,F2U : Fuse (250V, 3.15A (3)) (A1P)
- F5U : Field fuse
- F400U : Fuse (250V, 6.3A (C)) (A2P)
- H1P~H8P : Pilotlamp (Service monitor - orange)
- I12P1 : Prepare test
- I12P2 : Flickering
- HAP : Multifunction detection-- Light up
- HAP : Pilotlamp (Service monitor - green)
- K1 : Magnetic relay
- K2 : Magnetic contactor(M1C)
- K2M : Magnetic contactor(M2C)
- K1R : Magnetic Relais (K2M)
- K3R : Magnetic relay (Y1S)
- K4R : Magnetic relay (Y2S)
- K5R : Magnetic relay (Y3S)
- K7R : Magnetic relay (E1HC)
- K8R : Magnetic relay (E2HC)
- L1R : Reactor
- M1C : Motor (compressor)
- M1F : Motor (fan)
- PS : Switching power supply (A1PA3P)
- Q1RP : Phase reversal detect circuit
- Q1DI : Earth leakage breaker
- R10 : Resistor (Current sensor) (A4P)
- R50,R59 : Resistor
- R9S : Resistor (Current limiting)
- R1T : Thermistor (air) (A1P)
- R1T : Thermistor (fan) (A3P)
- R2T : Thermistor (Suction)
- R31T : Thermistor (discharge pipe) (M1C)
- R32T : Thermistor (discharge pipe) (M2C)
- R4T : Thermistor (Heat exch. device)
- R5T : Thermistor (Heat exch. outlet)
- R6T : Thermistor (liquid pipe)
- R7T : Thermistor (Accumulator)
- S1NPH : Pressure sensor (High)
- S1NPL : Pressure sensor (Low)
- S1PH, S2PH : Pressure switch (High)
- T1A : Safety device input
- V1R : Power module (A6P)
- V1R,V2R : Power module (A3P)
- X1A,X2A : Connector (M1F)
- X1M : Terminal strip (Power supply)
- X1M : Terminal strip (Control) (A1P)
- X1M : Terminal strip (A5P)
- Y1E : Electronic expansion valve (Main)
- Y1S : Solenoid valve (Hot gas)
- Y2S : Solenoid valve (oil return)
- Y3S : Solenoid valve (4-way valve)
- Z1C~Z5C : Noise filter (ferite core)
- Z1F : Noise filter (with surge absorber)

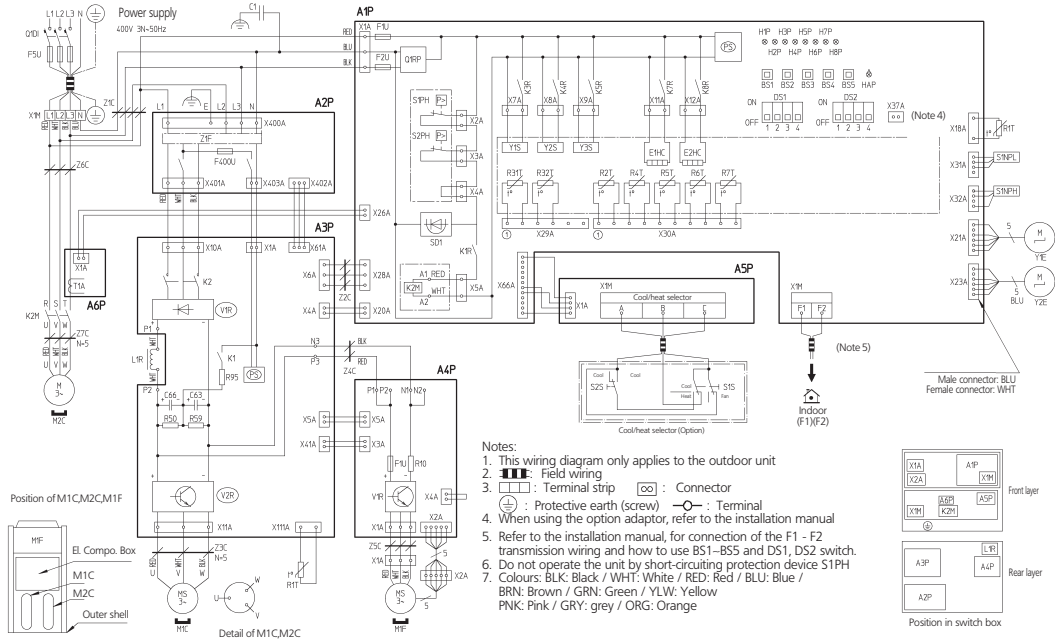

- Notes:
1. This wiring diagram only applies to the outdoor unit
 2. ■■■ : Field wiring
 3. □ : Terminal strip ⊞ : Connector
 4. When using the option adaptor, refer to the installation manual
 5. Refer to the installation manual, for connection of the F1 - F2 transmission wiring and how to use B51~B55 and DS1, DS2 switch.
 6. Do not operate the unit by short-circuiting protection device S1PH
 7. Colours: BLK: Black / WHT: White / RED: Red / BLU: Blue / BRN: Brown / GRN: Green / YLW: Yellow / PNK: Pink / GRY: grey / ORG: Orange

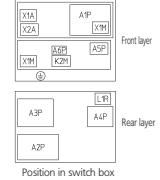

2TW32056-1

11 External connection diagrams

11 - 1 External Connection Diagrams

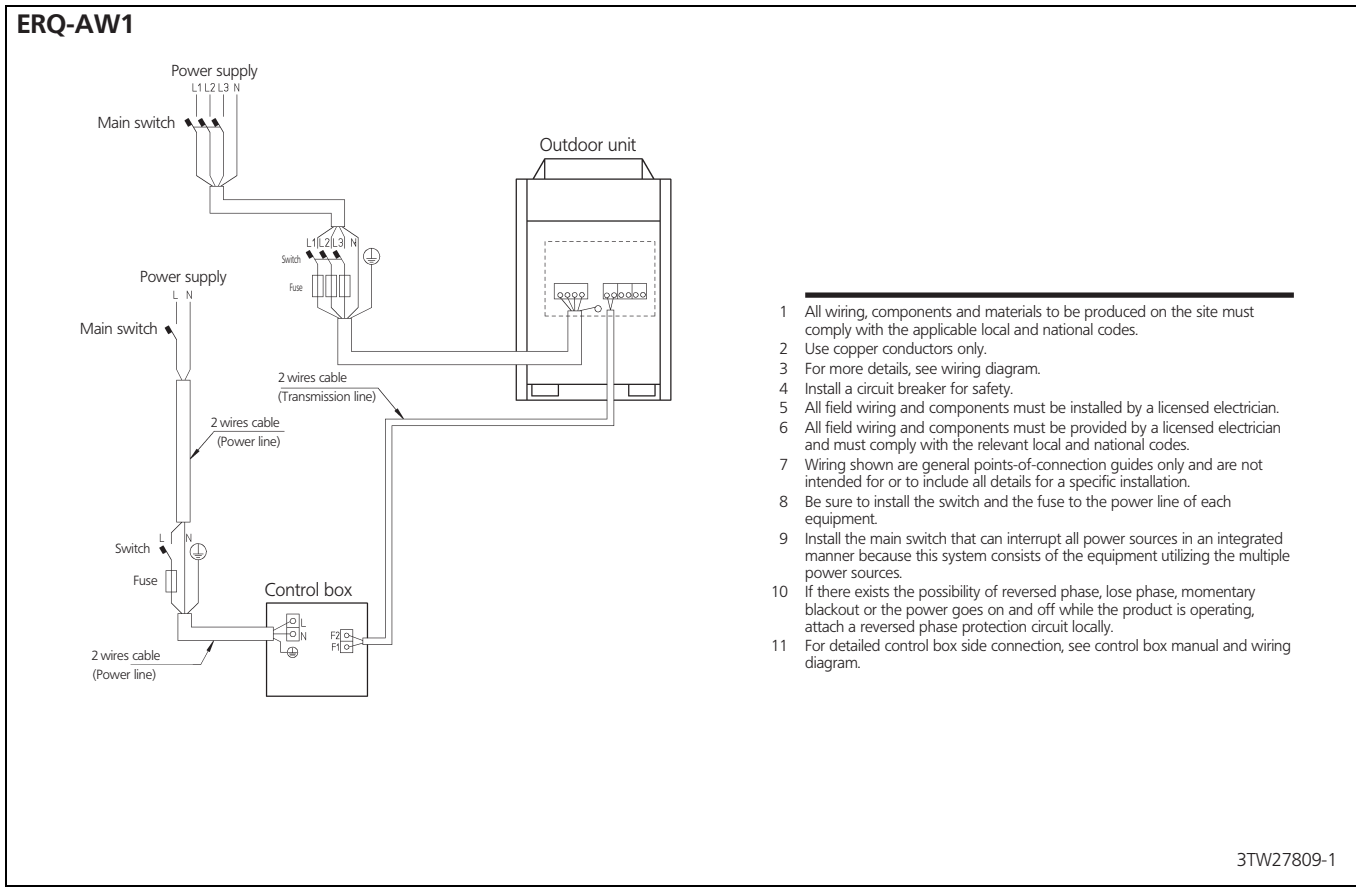

12 Sound data

12 - 1 Sound Power Spectrum

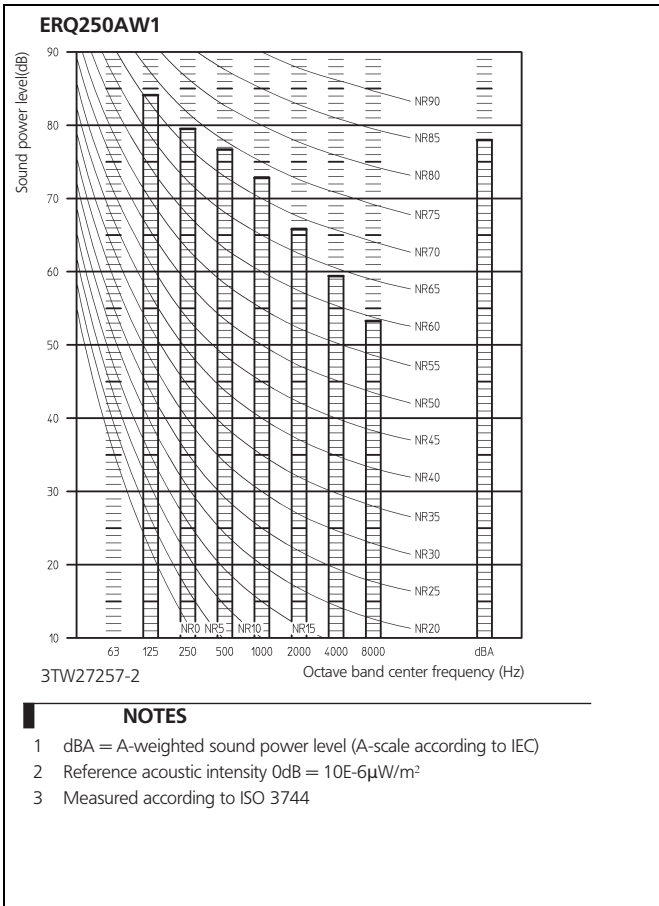
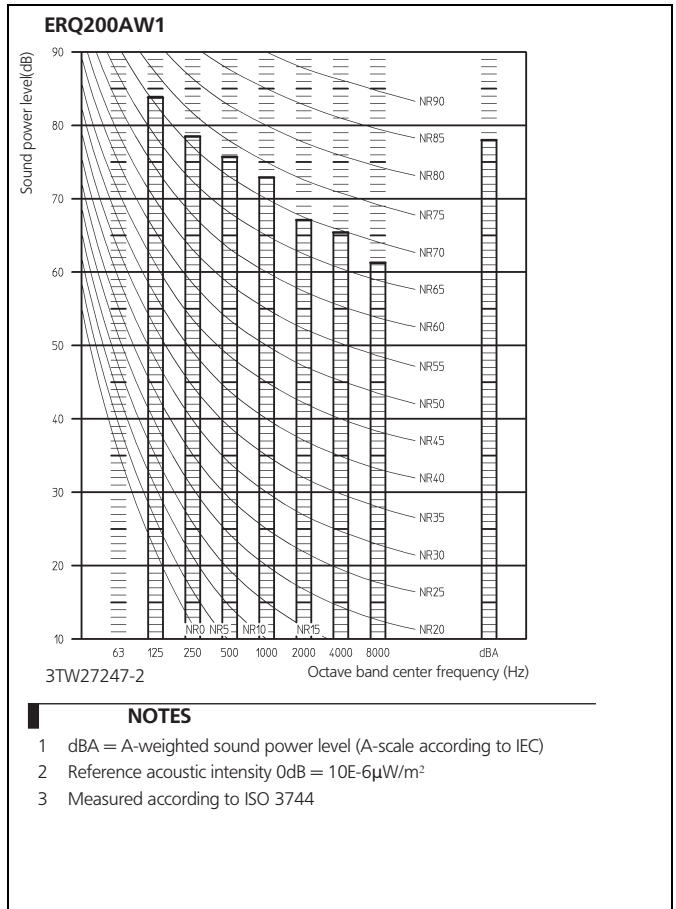
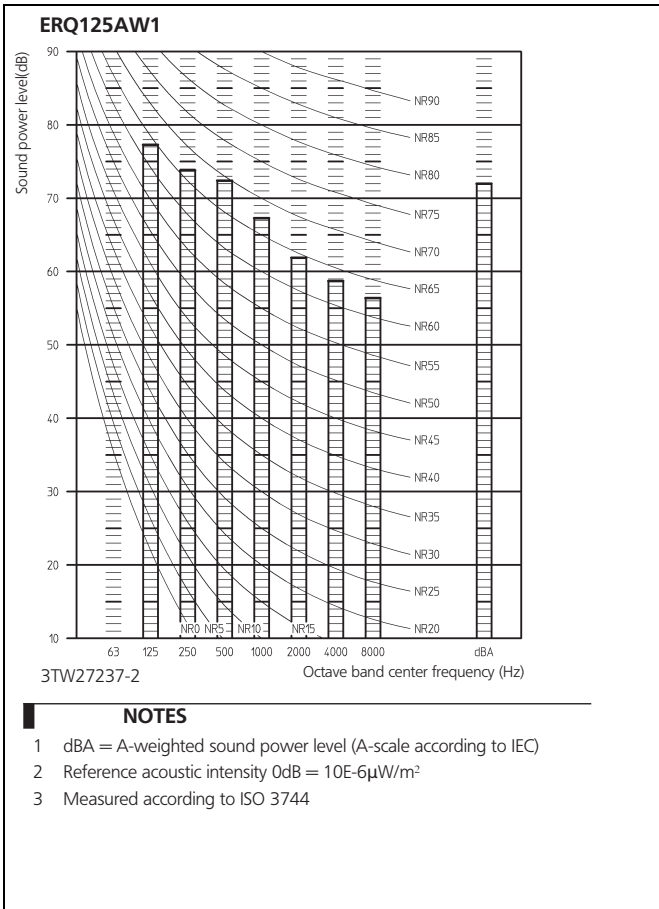

12 Sound data

12 - 2 Sound Pressure Spectrum

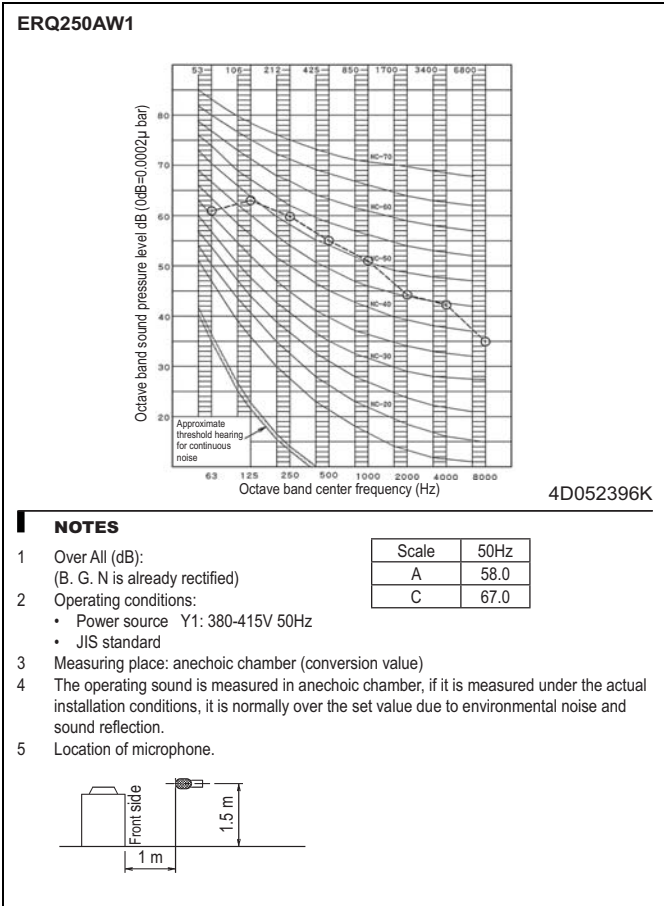
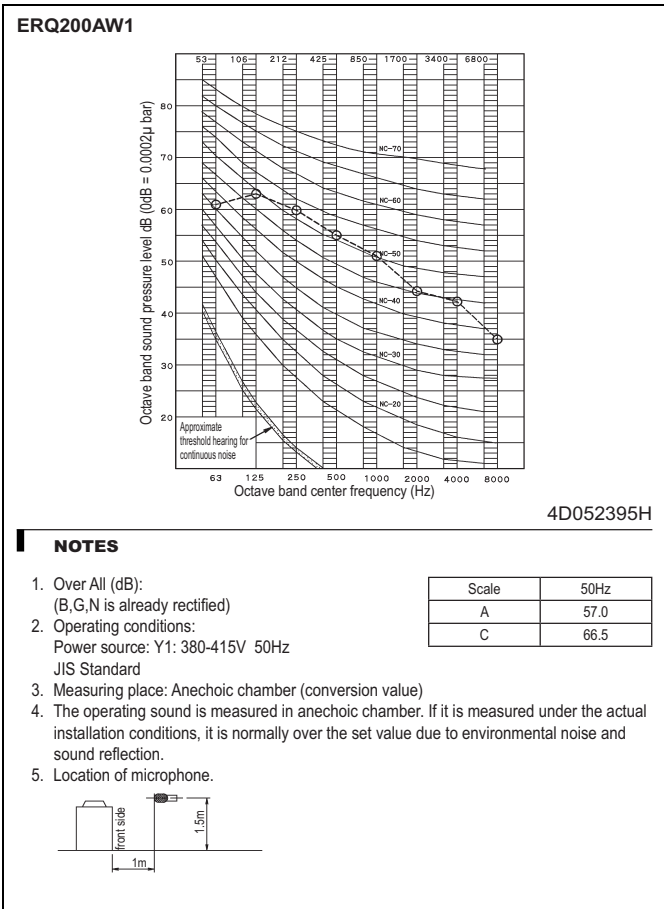
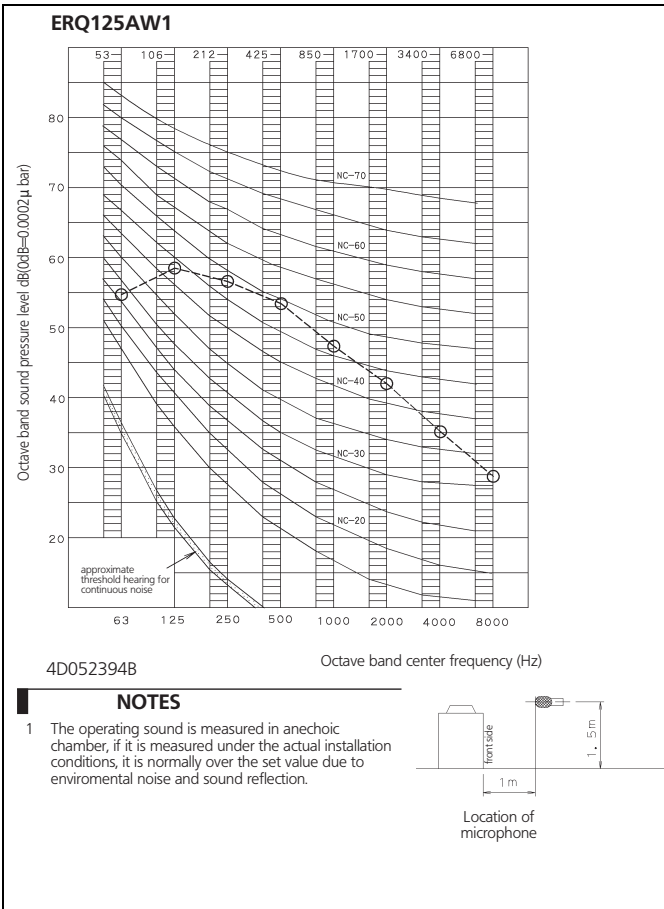

13 Installation

13 - 1 Installation Method

13

ERQ-AW1

For single unit installation

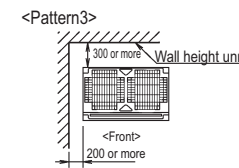
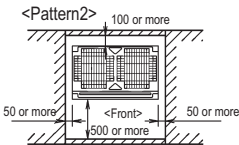
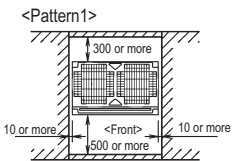

For installation in rows

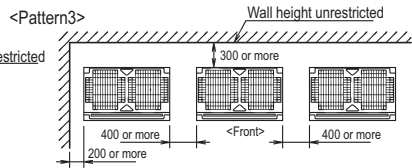
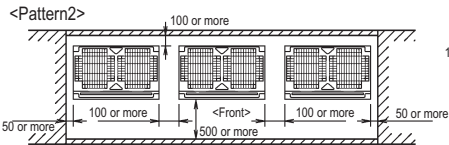
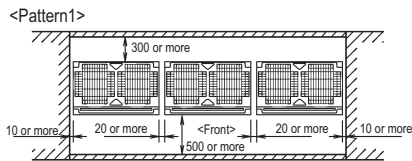

For centralized group layout

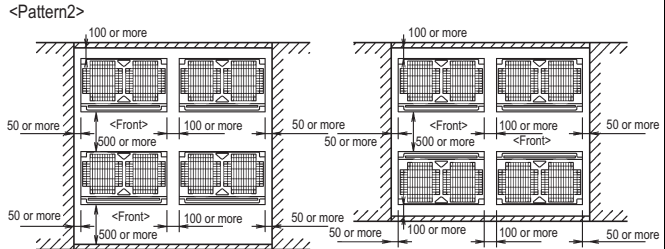
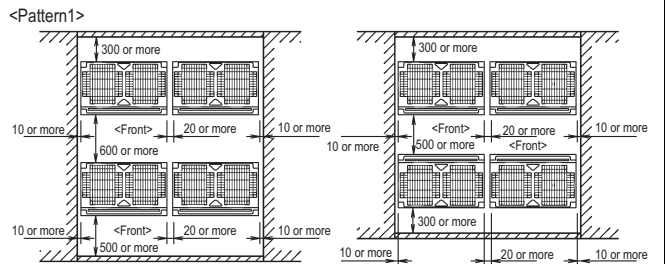

<Unit: mm>

NOTES

- Heights of walls in case of Patterns 1 and 2:
Front: 1500mm
Suction side: 500mm
Side: Height unrestricted
Installation space to be shown in this drawing is based on the cooling operation at 35 degrees outdoor air temperature. When the design outdoor air temperature exceeds 35 degrees or the load exceeds maximum ability because of much generation load of heat in all outdoor units, take the suction side space more broadly than the space to be shown in this drawing.
- If the above wall heights are exceeded then h2/2 and h1/2 should be added to the front and suction side service space respectively as shown in the figure on the right.
- When installing the units most appropriate pattern should be selected from those shown above in order to obtain the best fit in the space available always bearing in mind the need to leave enough space for a person to pass between units and wall and for the air to circulate freely. (If more units are to be installed than are catered for in the above patterns your layout should take account of the possibility of short circuits.)
- The units should be installed to leave sufficient space at the front for the on site refrigerant piping work to be carried out comfortably.

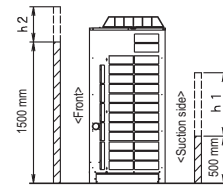

3D051451U

13 Installation

13 - 2 Fixation and Foundation of Units

ERQ-AW1

929
729
100
60°
100
80
80
80
Drain ditch
(Smooth down grade of about 1/50)
Y ditch
Except: 125 models
A
B
When building a foundation on the ground
When building a foundation on the concrete floor
Drain ditch
50
100
50
50
X - X Cross section

Nut
Spring washer
Frame
Foundation bolt
Type: JA
Size: M12
Four bolts are required
3 thread ridges or more
75
Foundation bolt executing method

60
A
60
A
When installing multiple units in connection

Model	A	B
ERQ135A7W1B	497	697
ERQ200A7W1B	792	992
ERQ250A7W1B	792	992

NOTES

- The proportions of cement: sand: gravel for the concrete shall be 1:2:4, and the reinforcement bars that their diameter are 10mm, (approx. 300mm intervals) shall be placed.
- The surface shall be finished with mortar. The corner edges shall be chamfered.
- When the foundation is built on a concrete floor, rubble is not necessary. However, the surface of the section on which the foundation is built shall have rough finish.
- A drain ditch shall be made around the foundation to thoroughly drain water from the equipment installation area.
- When installing the equipment on a roof, the floor strength shall be checked, and water-proofing measures shall be taken.
- Y Ditch is not necessary for 125 models.

3TW32039-6

14 Operation range

14 - 1 Operation Range

14

ERQ-AW1

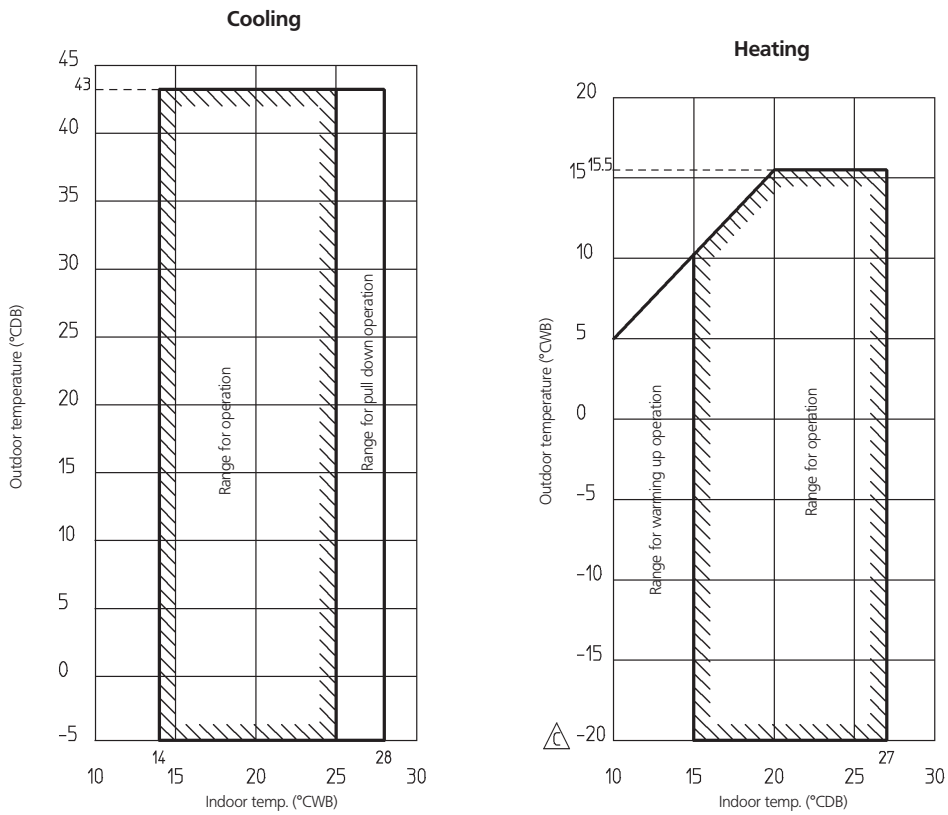

NOTES

- 1 These figures assume the following operating conditions.
Indoor and outdoor units:
 - Equivalent piping length 7.5m
 - Level difference 0m
- 2 Depending on operation and installation conditions, the indoor unit can change over to freeze-up operation (indoor de-icing).
- 3 To reduce the freeze-up operation (indoor de-icing) frequency it is recommended to install the outdoor unit in a location not exposed to wind.

4TW25797-3C



These products are not within the scope of the Eurovent certification program

The present leaflet is drawn up by way of information only and does not constitute an offer binding upon Daikin Europe N.V.. Daikin Europe N.V. has compiled the content of this leaflet to the best of its knowledge. No express or implied warranty is given for the completeness, accuracy, reliability or fitness for particular purpose of its content and the products and services presented therein. Specifications are subject to change without prior notice. Daikin Europe N.V. explicitly rejects any liability for any direct or indirect damage, in the broadest sense, arising from or related to the use and/or interpretation of this leaflet. All content is copyrighted by Daikin Europe N.V.

BARCODE

Daikin products are distributed by: