



Compressor
Voltage Code : FZ

AE4460Y-FZ3C

High Temp. Commercial (HP)

220 - 240V 1~ 50 Hz

R134a / R513A

AE4460Y-FZ3C

Conditions	Frequency	Nominal Cooling Capacity		Sound Power ISO3745 / ISO 3743-1
		Watts	BTU/h	
EN12900 / R134a	50 Hz	1338	4561	60 dBA
EN12900 / R513A	50 Hz	1361	4640	60 dBA

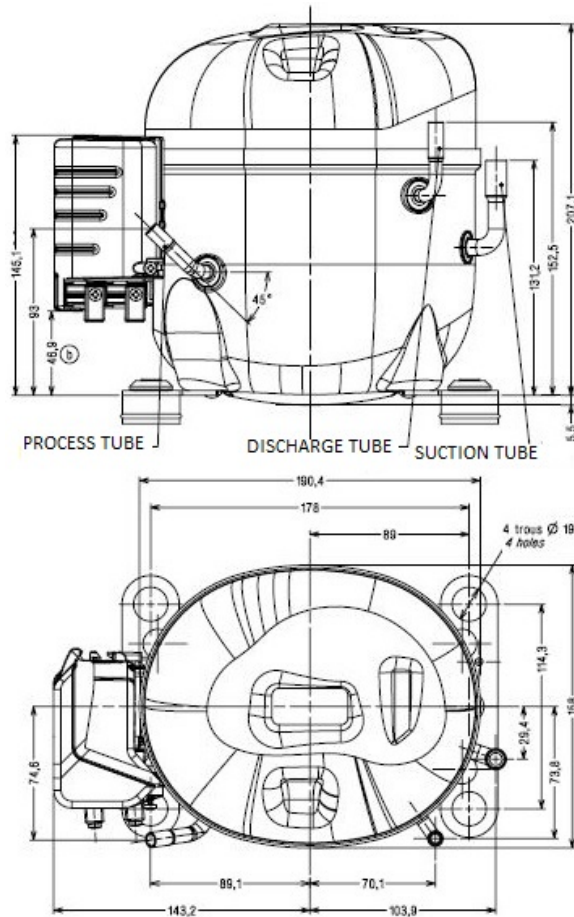

* EN12900 : T°Cond. 50.0°C / T°Evap. 5.0°C / T°Return gas temp.. 20.0°C
T°Subcooling. 0.0K

Certificates :



Displacement (cc)	15.09
Net Weight (Kg)	11.3
Oil Quantity (cc)	380.0
Oil Type	Polyolester
Expansion Device	Capillary_Tube/Expansion_Valve
Cooling	Fan
Main Winding (Ohm)	4.09
Start Winding (Ohm)	20.81
Current	
RLA (A)	3.1
LRA (A)	18.5
Electrical Equipment	CSR
Overload	T7905
Time Check	6.5s - 16s / 11.00 A
Open Temp	120° C
Close Temp	61° C
Start Capacitor	72 µF / 330 V
Run Capacitor	7.5 µF / 400 V
Potential Relay	RVA4P**
Pick Up	300/328V
Drop Out	60/121V
Refrigerating connection for OD	
Suction Tube	9.5 (3/8")
Discharge Tube	6.35 (1/4")
Process Tube	6.35 (1/4")

Note : Tecumseh reserves the right to change information contained in this document without notification.



Tecumseh

AE4460Y-FZ3C	Tension FZ : 220 - 240V 1~ 50 Hz
---------------------	---

Les performances sont données dans les conditions EN12900 :	Gaz aspirés :	20.0 °C
Condition Dew	Sous refroidissement :	0.0 K
The performance data are in EN12900 conditions :	Return gas :	20.0 °C
Dew Condition	Subcooling :	0.0 K

50 Hz R134a											
N°3108											
4 T condensation	5 T évaporation	(°C)	-25	-20	-15	-10	-5	0	5	10	15
30	1 P frigorifique	(Watt)	431	572	735	926	1149	1409	1711	2058	2457
	2 P absorbée	(W)	265	302	334	365	395	427	462	502	548
	3 I absorbée	(A)	1.62	1.73	1.85	1.97	2.10	2.23	2.37	2.52	2.67
40	1 P frigorifique	(Watt)	355	492	646	822	1026	1261	1533	1846	2205
	2 P absorbée	(W)	267	315	357	396	433	470	509	552	600
	3 I absorbée	(A)	1.61	1.76	1.91	2.07	2.24	2.41	2.59	2.77	2.96
50	1 P frigorifique	(Watt)		406	548	707	889	1098	1338	1614	1931
	2 P absorbée	(W)		319	373	422	468	514	559	607	659
	3 I absorbée	(A)		1.79	1.99	2.18	2.39	2.60	2.81	3.03	3.26
60	1 P frigorifique	(Watt)			450	591	748	928	1133	1371	1644
	2 P absorbée	(W)			383	445	503	558	612	668	726
	3 I absorbée	(A)			2.06	2.30	2.54	2.79	3.04	3.30	3.56

50 Hz R513A											
N°3184											
4 T condensation	5 T évaporation	(°C)	-25	-20	-15	-10	-5	0	5	10	15
30	1 P frigorifique	(Watt)	496	646	815	1007	1225	1474	1757	2078	2441
	2 P absorbée	(W)	295	331	362	391	421	455	497	550	617
	3 I absorbée	(A)	1.80	1.90	2.00	2.11	2.24	2.38	2.55	2.76	3.00
40	1 P frigorifique	(Watt)	401	544	704	883	1085	1315	1575	1871	2205
	2 P absorbée	(W)	291	342	384	422	458	496	538	589	652
	3 I absorbée	(A)	1.76	1.91	2.06	2.21	2.37	2.54	2.74	2.96	3.21
50	1 P frigorifique	(Watt)		441	584	744	925	1129	1361	1624	1923
	2 P absorbée	(W)		339	397	447	493	539	586	639	700
	3 I absorbée	(A)		1.91	2.12	2.31	2.52	2.72	2.95	3.19	3.46
60	1 P frigorifique	(Watt)			473	607	759	931	1128	1354	1611
	2 P absorbée	(W)			400	467	527	583	639	698	762
	3 I absorbée	(A)			2.16	2.42	2.67	2.92	3.18	3.45	3.74

1 = cooling capacity 2 = power input 3 = current 4 = condensing temperature 5 = evaporating temperature

Nota : Tecumseh se réserve le droit de modifier les informations contenues dans ce document sans préavis.

Note : Tecumseh reserves the right to change information contained in this document without notification.

© 2020 Tecumseh Products Company
All rights reserved