

# ZIE BIJZONDERE VOORWAARDE(N)

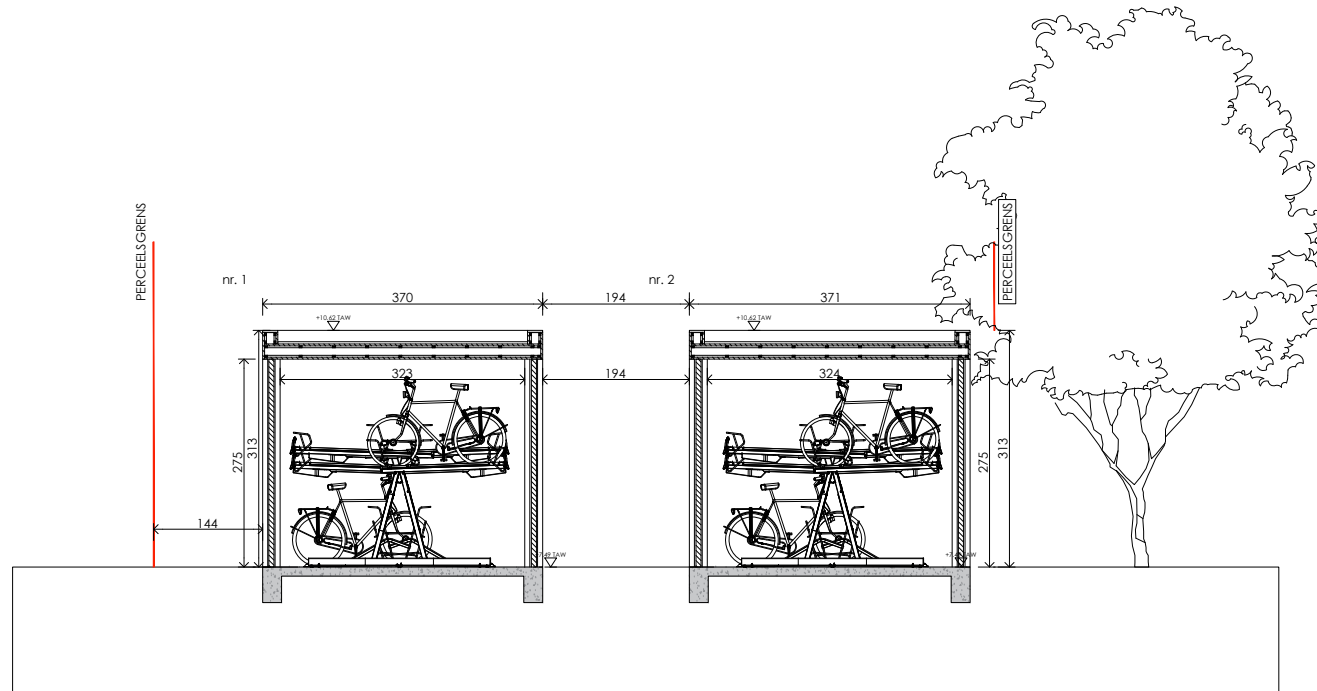

Snedes BB'



ZABRA REAL ESTATE  
Antoon Catriestraat 8a  
9031 DRONGEN  
T +32 9 365 60 85



BONTINCK ARCHITECTURE AND INTERIOR NV  
OTTERGENSESTEENWEG-ZUID 808 A31  
BE-9000 GENT | BELGIUM  
T +32 9 225 01 74 | F +32 9 225 64 14  
STUDIOGROEP@BONTINCK.BIZ | WWW.BONTINCK.BIZ

LOT 35 | FIETSENSTALLING  
Lange snede BB'

HOF VAN GENT

DOSSIERNR:	1367-17	DATUM:	30/03/2026
SCHAAL:	1/100	PLAN:	S_N_02